



Pre-amplifiers and integrated amplifiers

welcome

Thank you for buying a Chord product.

Before you start to enjoy using your Chord product, please take a couple of minutes to read how to connect your audio equipment and loudspeakers to your pre-amplifier or integrated amplifier and how to maximise your listening experience.

user guide for

pre-amplifiers

CPA 2200

CPA 3200E

CPA 4000E

integrated amplifiers

CPM 2600

CPM 3300

pre-amplifiers

CPA 2200, CPA 3200E, CPA 4000E

The pre-amplifier is the control centre of your system. By connecting your audio sources to it you can choose the source you want at any particular time and control it.

You can also adjust the balance and volume before the signal is sent to a power amplifier. Your pre-amplifiers can be operated manually or via the Chord remote control.

integrated amplifiers

CPM 2600, CPM 3300

Chord's integrated amplifiers are based on a combination of our highly successful pre-amplifiers and power amplifiers together with a few features of their own.

The power amplifier is based on Chord's tried and tested technology of ultra high frequency ESR power supply which has the ability to store more energy far more efficiently than conventional designs.

A variety of outputs means that you can choose to drive up to two sets of loudspeakers, use your integrated amplifier as a pre-amplifier or use it in conjunction with another power amplifier for bi-amping.

background

We want you to be confident using your new Chord amplifier.

You're probably an audiophile with extensive knowledge of audio equipment.

However, you may not be!

So in the following section we explain a few basics to help you get started, or get you back up to speed if you're a little rusty.

connecting your equipment

Chord amplifiers are supplied with and designed to be connected using balanced inputs. The interconnecting cables you use will depend on the available input and output sockets on your other equipment. We have installed unbalanced inputs on all Chord equipment, thus enabling you to mix Chord and other manufacturer's equipment.



Balanced inputs carry twice the strength of signal of unbalanced inputs and are able to be fed down long lengths of cable with less deterioration of signal. They are also less prone to interference than unbalanced inputs. Balanced inputs have three pins and use Neutric XLR style connectors. Pin 1 is earth, pin 2 is positive and pin 3 is negative.



Unbalanced inputs use RCA phono connectors which are gold plated with teflon high performance dielectric insulators for optimum performance.

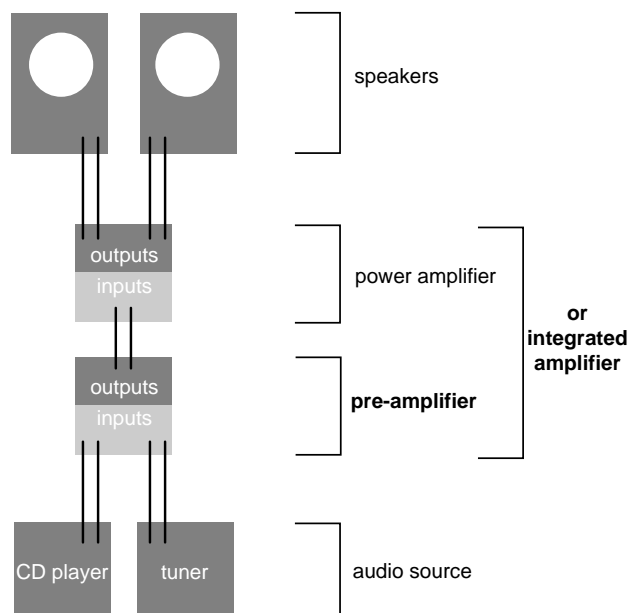

when setting up

To ensure that your Chord integrated amplifier works efficiently and safely, please pay particular attention to the following issues.

ventilation

Your Chord integrated amplifier should have at least 5cm of clear space all around it to ensure a free flow of air at all times. When driven continuously at well above average levels, the temperature at the back of the unit may exceed 50°C. This is normal and no cause for concern, although it does highlight the need for adequate ventilation around the unit. We recommend that you do not place your integrated amplifier directly on a carpet.

mains lead and plug

All Chord equipment comes supplied with the correct mains lead and plug. This should be used at all times.

if you need to fit a plug for UK/Europe

Connect the blue wire to the neutral terminal

Connect the brown wire to the live terminal

Connect the yellow/green wire to the earth terminal

if you need to fit a plug for US/Canada

Connect the white wire to the neutral terminal

Connect the black wire to the live terminal

Connect the green to the earth terminal

earthing issues in Europe

In some European countries a hum may occur if your integrated/pre-amplifier is connected to mains sockets that do not have an earth. If this is the case please ensure that:

1. Your integrated/pre-amplifier is connected via a multi-way mains block which contains an earth point at each socket outlet. This is to ensure that the chassis metalwork of each item is connected together.
2. Use the connecting points on your Chord unit and connect to an available earth point.
3. We recommend that an earthing method for your building is implemented.

safety warnings

It is important that your integrated/pre-amplifier is earthed at all times via its own mains lead. Failure to do this may be hazardous. The power supply components within the amplifier are designed to be operated at lethal voltages and energy levels. Circuit designs that embody these components conform with applicable safety requirements. Precautions must be taken to prevent accidental contact with power-line potentials. Do not connect grounded test equipment.

These units comply with EN 50081-1 and IEC 801/2

outputs on the CPA 2200

You need to connect the outputs on the back of your pre-amplifier to a power amplifier in order to drive your loudspeakers. There are three pairs of outputs, each of which will drive a 68 Ω load. You can connect to either the XLR or RCA outputs numbered 1, but not to both types at the same time.



connecting to your power amplifier if it has balanced XLR style inputs

1. Use XLR style connectors to connect Right O/P 1 to Right IN on your power amplifier, and connect Left O/P 1 to Left IN on your power amplifier.
2. On your remote control press PRE and then O/P 1 to select output 1.



connecting to your power amp if it has unbalanced RCA style inputs

1. Use RCA style connectors to connect Right O/P 1 to Right IN on your power amplifier, and connect Left O/P 1 to Left IN on your power amplifier.
2. On your remote control press PRE and then O/P 1 to select output 1.



if you want to bi-amp

Bi-amping is a technique where you use one amplifier to drive the loudspeakers' woofers (low frequencies) and another to drive the tweeters (mid and high frequencies).

1. Use XLR style connectors to connect Right and Left O/P 1 to your first power amplifier.
2. Use XLR style connectors to connect Right and Left O/P 2 to your second power amplifier.
3. Connect the outputs of your first power amplifier to your loudspeaker's low frequency inputs.
4. Connect the outputs of your second power amplifier to your loudspeaker's high frequency inputs.
Remove any shorting links in the speaker binding posts.
5. On your remote control press PRE and then OP 1/2 to select both outputs 1 and 2.
See Figure 1 on page 19 for wiring details.

outputs on the CPA 3200E CPA 4000E

You need to connect the outputs on the back of your pre-amplifier to a power amplifier in order to drive your loudspeakers. There are three pairs of outputs, each of which will drive a 68 Ω load. You can connect to either the XLR or RCA outputs numbered 1, but not to both types at the same time.



connecting to your power amplifier if it has balanced XLR style inputs

1. Use XLR style connectors to connect Right O/P 1 to Right IN on your power amp, and connect Left O/P 1 to Left IN on your power amplifier.
2. On your remote control press PRE and then O/P 1 to select output 1.



connecting to your power amplifier if it has unbalanced RCA style inputs

1. Use RCA style connectors to connect Right O/P 1 to Right IN on your power amplifier, and connect Left O/P 1 to Left IN on your power amplifier.
2. On your remote control press PRE and then O/P 1 to select output 1.



if you want to bi-amp

Bi-amping is a technique where you use one amplifier to drive the loudspeakers' woofers (low frequencies) and another to drive the tweeters (mid and high frequencies).

1. Use XLR style connectors to connect Right and Left O/P 1 to your first power amplifier.
2. Use XLR style connectors to connect Right and Left O/P 2 to your second power amplifier.
3. Connect the outputs of your first power amplifier to your loudspeaker's low frequency inputs.
4. Connect the outputs of your second power amplifier to your loudspeaker's high frequency inputs.
Remove any shorting links in the binding posts.
5. On your remote control press PRE and then OP 1/2 to select both outputs 1 and 2.
See figure 1 on page 19 for wiring details.

headphones

CPA 4000

to turn on headphone mode

1. Insert the headphone jack(s).
2. Press the SET button several times until H-PHN is displayed.

Headphone mode automatically mutes your loudspeakers. Headphone mode also prevents any volume control from automatically unmuting your loudspeakers.

to turn off headphone mode

1. Press the SET button several times until your chosen output is displayed or
2. Press Mute on your remote control or
3. Press either OUT1, OUT2 or OUT1/2 on your remote control.

outputs on the CPM 2600 CPM 3300

You need to connect the outputs on the back of your integrated amplifier to your loudspeakers. You can use any speakers that match the output power of your amplifier. Note that the lower the impedance of your speakers the higher the output power.

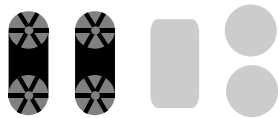

connecting to your loudspeakers

1. The loudspeaker connections are via two heavy duty WBT gold plated binding posts labelled O/P 1 and these should be connected to your speakers.
2. On your remote control press PRE and then O/P 1 to output the signal to your loudspeakers.

Note: The WBT rhodium plated 4mm speaker binding posts will accept 4mm banana plugs (WBT-0645 or WBT-0644) or 6mm spades (WBT-0680). Making connections using bare wire is not recommended.



using your integrated amplifier as a pre-amplifier

You can use your integrated amplifier as a pre-amplifier to provide a signal for another power amplifier.

1. Use RCA style connectors to connect Right O/P 2 to the Right IN on your power amplifier, and connect Left O/P 2 to the Left IN on your power amplifier.
2. On your remote control press PRE and then O/P 2 to output the signal to the power amplifier.

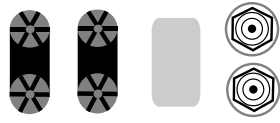

if you want to bi-amp

Bi-amping is a technique where you use one amplifier to drive the woofers (low frequencies) and another to drive the tweeters (mid and high frequencies).

1. Connect your loudspeakers' low frequency inputs to the binding posts labelled Right and Left O/P 1.
2. Use RCA style connectors to connect Right O/P 2 to the Right IN on your power amplifier, and connect Left O/P 2 to the Left IN on your power amplifier.
3. Connect the outputs of your power amplifier to your loudspeaker's high frequency inputs.
Remove any shorting links in the speaker binding posts.
4. On your remote control press PRE and then OP 1/2 to select both outputs 1 and 2.
See Figure 2 on page 19 for more details.

inputs on the CPA 2200

You can connect up to six items of source input equipment, such as CD player, Video, Tuner etc. to the inputs on your amplifier. The inputs have left and right sockets and use RCA phono connectors.

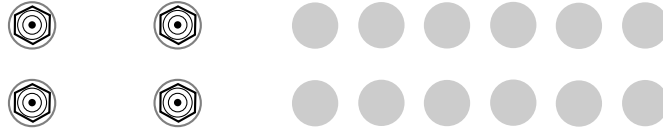

connecting to a CD or record player unit

Use RCA connectors to the LEFT and RIGHT pairs marked Disc 1 or Disc 2.

Note: All record players need to be connected to a separate phono head amplifier like the Chord Phono Stage before connecting to this product.

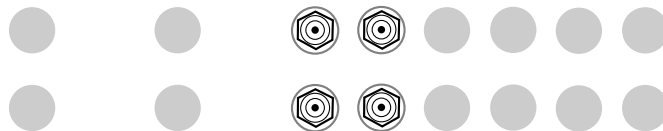

connecting to a Video, DVD, or other products

Use RCA connectors to the left and right pairs marked V.

connecting to a Tuner/Radio or Satellite receiver

Use RCA connectors to the left and right pairs marked R.

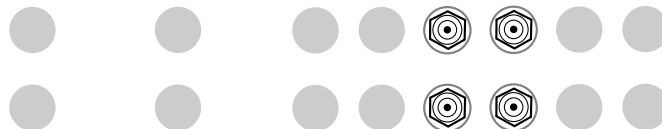

connecting to a Tape recorder

Use RCA connectors to the left and right pairs marked IN T1 or T2.

if you want to tape record

Refer to page 12 for more information.

inputs on the CPA 3200E CPA 4000E CPM 2600 CPM 3300

You can connect up to six items of source input equipment, such as CD player, Video, Tuner etc. to the inputs on your pre-amplifier or integrated amplifier.

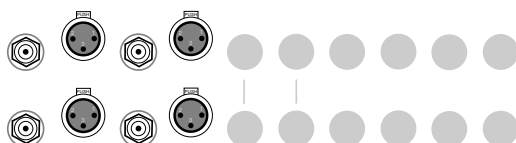

connecting to a CD or record player unit

1. Use either XLR or RCA connectors to the left and right pairs marked DISC 1 or DISC 2.
2. You can connect to either of the left/right pairs numbered 1 or 2, but not both 1s or both 2s at the same time.

Note: All record players need to be connected to a separate phono head amplifier like the Chord Phono Stage before connecting to this product.

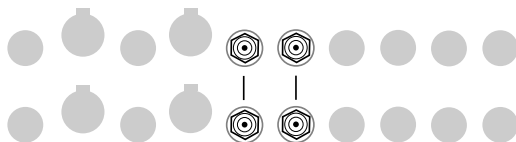

connecting to a Video, DVD or other products

Use RCA connectors to the left and right pairs marked V.

connecting to a Tuner/Radio or Satellite receiver

Use RCA connectors to the left and right pairs marked R.

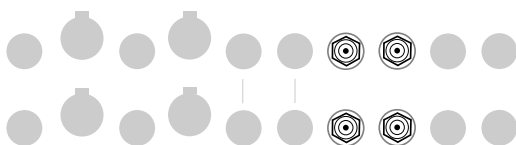

connecting to a Tape recorder:

Use RCA connectors to the left and right pairs marked IN T1 or T2.

if you want to tape record

Refer to page 12 for more information.

tape recording

You can tape record an input from another audio source or two sources at the same time. If you've been using a tape recorder as an input source, it will already be connected to the T1 or T2 IN sockets. If you haven't, first connect the tape's output to the T1 or T2 IN sockets.

connecting to a Tape recorder to tape an audio source

Use RCA connectors to the left and right pairs marked OUT T1 or T2, or both.

CPA 2200



CPA 3200E, CPA 4000E, CPM 2600, CPM 3300

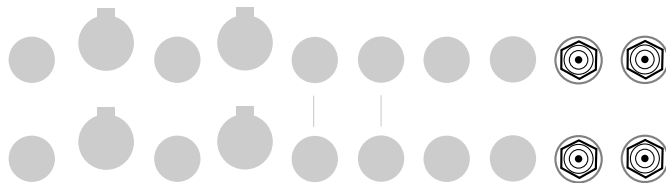

selecting the bus

Your amplifier has two input selection buses. The default bus is bus A and this is the one you would use to choose your inputs in everyday operation. The advantage of having two buses is that it allows for two tape recorders to tape (different inputs) simultaneously.

Bus A is permanently connected to the Tape 2 (T2) output and Bus B is permanently connected to Tape 1 (T1) output which prevents you from accidentally taping to and from the same machine.

You can tape from any source to either of the tape recorder outputs and both outputs can be monitored. For example you can play a CD on Disc 1 on Bus A and connect your tape recorder to the Tape 2 output while you play a record on Disc 2 on Bus B and connect another tape recorder to the Tape 1 output. Simply switch between Bus A and Bus B to monitor either of the sources.

everyday use

turning on your integrated/pre-amplifier

1. When you plug your amplifier into the mains using the supplied mains lead the power indicator on the front panel will glow red which means that the amplifier is in standby mode.
2. Press the power button beneath the power indicator and after a few seconds it will glow green indicating that the amplifier is ready for use.

automatic shutdown

1. If there is a major overload or short circuit the integrated amplifier will detect this and shut down automatically and the power indicator will fade and switch to red. The integrated amplifier should then be switched off immediately at the mains.
2. When the fault has been rectified the integrated amplifier can be switched on and will power up as usual. You should wait at least two minutes before turning the integrated amplifier on again at the mains to allow the power supply protection circuitry to reset itself.

select your input source

Your integrated/pre-amplifier uses input bus A by default and the display will read

DISC1 .

To scroll through the other input sources press button A. Press button B to select Bus B. It is indicated by a dot

displaying between each letter
D.I.S.C.1 .

Press button A to select:

DISC1

DISC2

VIDEO

RADIO

TAPE2

Press button B to select:

D.I.S.C.1

D.I.S.C.2

V.I.D.E.O.

R.A.D.I.O.

T.A.P.E.1

adjusting the volume

Use the volume knob to adjust the volume manually.

changing the balance

Use the balance knob to shift the balance between the left and right loudspeaker.

using the remote control

Your remote control is a universal controller for all Chord products.

This can provide a totally integrated audio solution. For the purposes of your pre-amplifier or integrated amplifier however, we need only concern ourselves with the buttons that are labelled in RED, as shown in the illustration on the next page.

For optimum use hold your remote control flat and point it directly at your integrated/pre-amplifier.

selecting your input source

1. Press PRE then Bus-A.
2. Press one of: Disc 1, Disc 2, Tape 2, Video or Radio.

adjusting the volume

1. Press the volume button marked ▲ to increase the volume.
2. Press ▼ to decrease the volume. The volume chosen will be displayed on the digital display with figures from 0 to 98.

choosing your output

1. Press O/P 1 if your output is connected to O/P 1 on the back of your integrated amplifier.
2. Press O/P 2 if you are using the line output from O/P 2 on the back of your integrated amplifier.
3. Press OP 1/2 if you are bi-amping.

Note: With the CPM2600 and CPM3300 integrated amplifiers, O/P 1 is internally connected to the internal amplifier stage. O/P 2 is the pre-amplifier output for connecting to an additional external amplifier.

changing the balance

1. Press the balance button marked ► to move the balance towards the right.
2. Press ◀ to move the balance to the left. The direction you are moving the balance towards will be displayed on the digital display.

mute

1. Press Mute to mute the amplifier.

to unmute

1. Press Mute again to unmute or
2. Press the volume buttons up or down or
3. Turn the volume knob on your amplifier up or down.

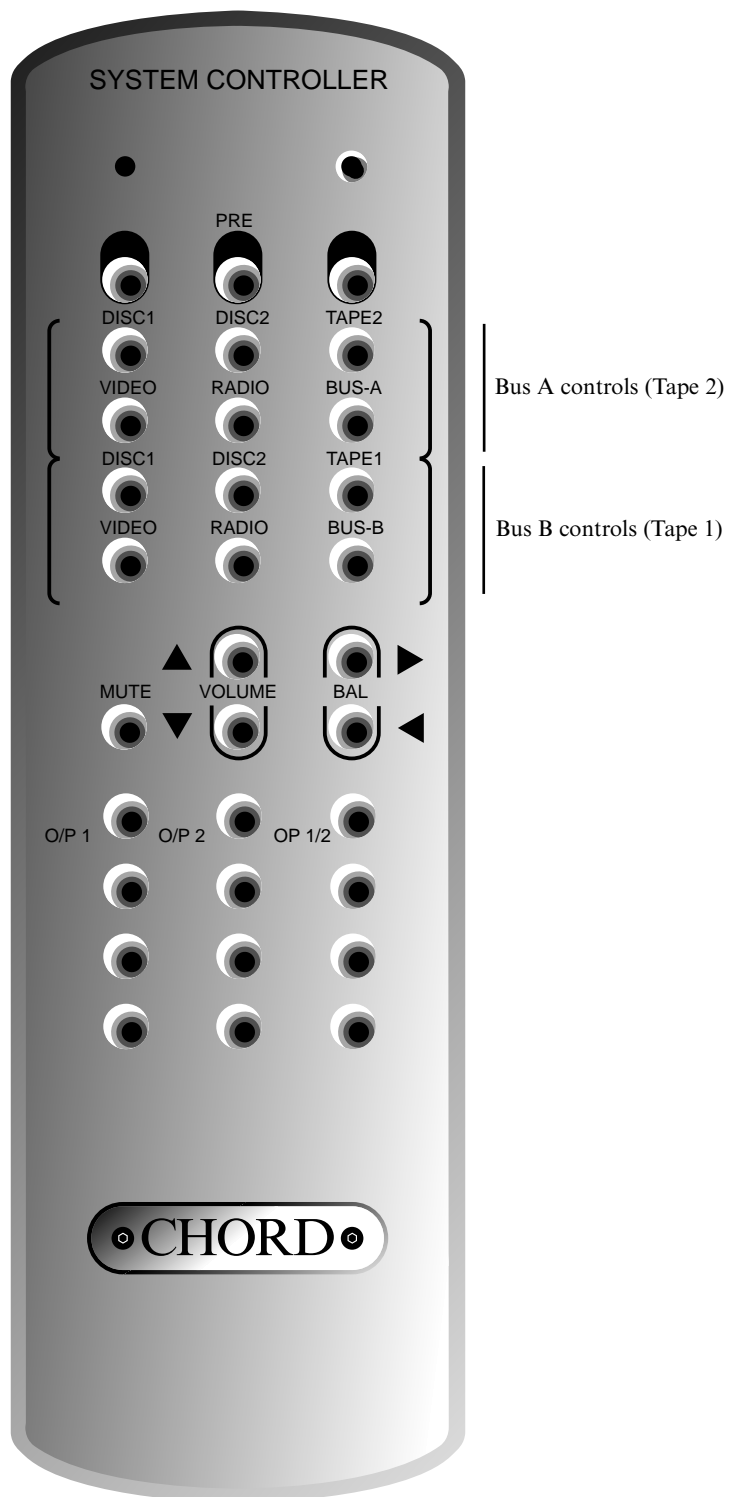

input gain control

CPM 3300, CPA 3200E, CPA 4000E

You can adjust the input gain on your input devices so that you can align the volume levels of your different inputs. There are four settings which are x1, x1.5, x1.75 and x2. This feature is not available on the CPA 2200 and the CPM 2600.

Most modern input devices such as CD players have an unbalanced output voltage of 2V and a balanced output of 4V which does not require any amplification. In fact, to increase the gain on such an output level can lead to a distortion of the signal.

However, older audio equipment may have an output voltage of less than 2V, in which case you may like to adjust the input gain.

increasing the input gain

1. Using your remote control press PRE and then the input device of your choice (eg Disc 1). The display will show **DISC1**.
2. Press BUS-A (or BUS-B if you are going to record from the Tape 1 output). The display will show **GAIN1**.
3. Press the volume button marked ▲ to increase the gain to x1.5. The display will show **x1.50**.
4. Repeat steps 2 and 3 to increase the gain to x1.75, and repeat these steps once again to increase the gain to x2.

reducing the input gain

1. Using your remote control press PRE and then the input device of your choice (eg Disc 1). The display will show **DISC1**.
2. Press BUS-A (or BUS-B if you are going to record from the Tape 1 output).
3. Press the volume button marked ▼ to decrease the gain.
4. Repeat steps 2 and 3 to reduce the gain again.

Once you have adjusted the gain setting on an input device your amplifier will remember the setting, even if it is switched off for many months.

to reset all gain levels to x1 on Bus A and Bus B

1. On the front of your amplifier press and hold the A button for three seconds. The display will show a gain setting, for example **x1.50**.
2. Press and hold the Set(S) button until you see **RESET** then release the button and the display will show five dashes **-----**.
3. Select a source on either bus system.

maintenance

adjusting the settings

Always remember to make any changes to settings with the volume set low or an instant burst of sound could damage your loudspeakers

cleaning

To clean finger marks and other blemishes from your amplifier spray clear glass cleaner onto a soft lint free cloth and then use the cloth to gently clean your amplifier.

changing the batteries in the remote control

Simply undo the four small cross head screws on the side of your remote control. You may need to run a sharp knife along the join to remove the battery casing, then replace with four new AAA batteries as shown inside the battery compartment.

servicing

There are no user serviceable parts in your Chord amplifier, and it should only be serviced by Chord Electronics Limited or their expressly approved Service Agents.

frequently asked questions

why aren't any of the remote control buttons working?

Press Pre to set up the remote control for pre-amplifier functions.

I've connected all the wires up but I can't hear any sound?

Ensure that you've selected the correct bus (typically Bus A), the correct input (eg Disc 1) and the correct output (eg Output 1).

why is there no display when I've turned the amplifier back on?

You need to wait for two minutes after switching the unit off before switching it on again.

why is there humming coming from the loudspeakers?

Check that you've earthed the unit. The interconnects need to be properly screened and placed away from mains cables. Interference can be reduced by using balanced inputs and outputs instead of RCA phono types.

the sound coming from the loudspeakers is distorted

Check that the speakers are connected properly. It may be that the volume is turned up too loud for your speakers or that you have set the gain for the input device too high.

the amplifier was in standby mode and has turned itself off

Changing connections while the amplifier is on, for example, dropping the stylus onto a record can cause the unit to shutdown. Check that the speaker cables have no stray inner core wires touching each other as this can cause a short circuit.

bi-amping

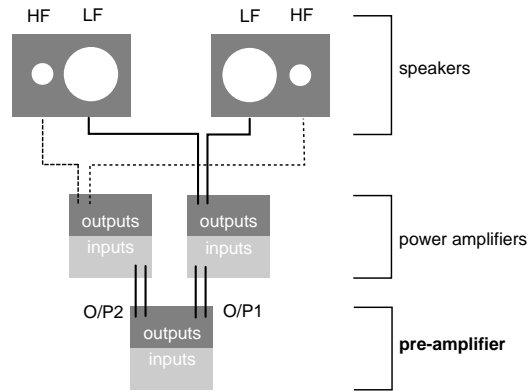

Figure 1: Bi-amping for a pre-amplifier

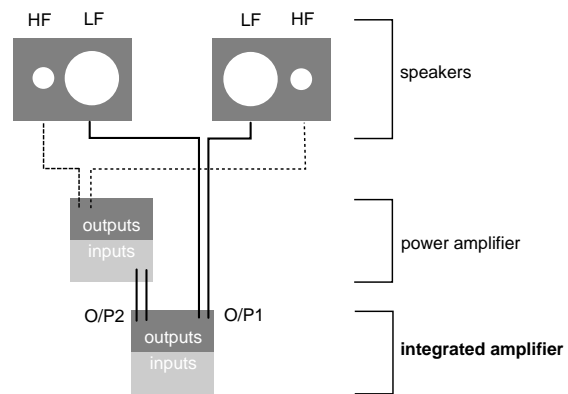

Figure 2: Bi-amping for an integrated amplifier

pre-amplifiers technical information

	CPA 2200	CPA 3200E	CPA 4000E
harmonic distortion	10Hz -90dB	10Hz -97dB@gain1	10Hz -97dB@gain1
	1kHz -91dB	1kHz -97dB@gain1	1kHz -97dB@gain1
	10kHz -89dB	10kHz -96dB@gain1	10kHz -96dB@gain1
	20kHz -87dB	20kHz -98dB@gain1	20kHz -98dB@gain1
intermodulation distortion			
all inputs	-100dB	-100dB	-100dB
signal to noise ratio	-93dB	-93dB	-93dB
Video input	-83dB	-83dB	-83dB
channel separation			
	10Hz 110dB	10Hz 125dB	10Hz 125dB
	1kHz 100dB	1kHz 105dB	1kHz 105dB
	10kHz 91dB	10kHz 93dB	10kHz 93dB
	20kHz 89dB	20kHz 93dB	20kHz 93dB
channel balance	0.01dB	0.01dB	0.01dB
potentiometer performance	0dB -20dB -60dB 0.5dB 0.2dB 0.24dB 17 secs ±3 secs for full travel of 300°	as CPA 2200	as CPA 2200
balanced inputs	NA	Disc 1 and Disc 2 XLR and RCA wired asymmetrically in parallel	as CPA 3200
unbalanced inputs			
Disc 1	yes	yes	yes
Disc 2	yes	yes	yes
Video	yes	yes	yes
Radio	yes	yes	yes
Tape 1	yes	yes	yes
Tape 2	yes	yes	yes
outputs			
balanced XLR			
O/P 1 & 2	2 pairs	2 pairs	2 pairs
unbalanced RCA	1	1	1
unbalanced RCA	2 for tape	2 for tape	2 for tape 2 headphone
frequency range	2.5Hz-200kHz (-3dB)	as CPA 2200	as CPA 2200
input max			
Disc 1	3.6V rms	8V rms (balanced) 4V rms (unbalanced)	8V rms (balanced) 4V rms (unbalanced)
Disc 2	3.6V rms	8V rms (balanced) 4V rms (unbalanced)	8V rms (balanced) 4V rms (unbalanced)
Video	3.6V rms	3V rms	3V rms
Radio	3.6V rms	3V rms	3V rms
Tape 1	3.6V rms	3V rms	3V rms
Tape 2	3.6V rms	3V rms	3V rms
nominal gain	1V AC in 2V AC out	All channels have 4 levels of gain x1, x1.5, x1.75, and x2 Video signal has additional x4	as CPA 3200E
input impedance			
balanced	-	94k Ω	as CPA 3200E
unbalanced	47k Ω	47k Ω	
output max			
	15.6V rms (balanced) 7.8V rms (unbalanced)	15V rms (balanced) 7.5V rms (unbalanced)	15V rms (balanced) 7.8V rms (unbalanced)
output impedance			
short circuit protected	100 Ω	100 Ω	100 Ω
output offset	L/R 0mV both channels	as CPA 2200	as CPA 2200
dimensions			
mm/w/h/d	420 x 88 x 355	420 x 133 x 355	420 x 155 x 355
weight	13kg	14kg	18kg

integrated amplifiers technical information

	CPM 2600	CPM 3300
output power	120w rms per channel 0.05% distortion into 8 Ω	220w rms per channel 0.05% distortion into 8 Ω
harmonic distortion	10Hz -91dB 1kHz -93dB 10kHz -90dB 20kHz -87dB	10Hz -91dB 1kHz -93dB 10kHz -90dB 20kHz -87dB
intermodulation distortion	all inputs -100dB	-100dB
signal to noise ratio	-93dB	-93dB
channel separation	10Hz 90dB 1kHz 90dB 10kHz 90dB 20kHz 85dB	10Hz 90dB 1kHz 90dB 10kHz 90dB 20kHz 85dB
channel balance	0.01dB	0.01dB
potentiometer performance	0dB -20dB -60dB 17 secs \pm 3 secs for full travel of 300°	as CPM 2600
balanced inputs	Disc 1 and Disc 2 XLR and RCA wired asymmetrically in parallel	as CPM 2600
unbalanced inputs		
Disc 1	yes	yes
Disc 2	yes	yes
Video	yes	yes
Radio	yes	yes
Tape 1	yes	yes
Tape 2	yes	yes
outputs		
1	1 pair WBT speaker binding posts	as CPM 2600
2	RCA unbalanced pre-amp out 2 for tape RCA unbalanced	
frequency range	2.5Hz-80kHz (-3dB)	2.5Hz-80kHz (-3dB)
input max		
Disc 1	8V rms (balanced) 7V rms (unbalanced)	8V rms (balanced) 7V rms (unbalanced)
Disc 2	8V rms (balanced) 7V rms (unbalanced)	8V rms (balanced) 7V rms (unbalanced)
Video	8V rms	8V rms
Radio	3V rms	3V rms
Tape 1	3V rms	3V rms
Tape 2	3V rms	3V rms
input impedance		
balanced	94k Ω	94k Ω
unbalanced	47k Ω	47k Ω
output max	15.6V rms balanced 7.8V rms unbalanced	15V rms balanced 7.5V rms unbalanced
pre-amp output impedance	470 Ω	100 Ω
output impedance	0.03 Ω	0.03 Ω
slew rate	70V per μ s. 1kHz 20V square wave	70V per μ s. 1kHz 20V square wave
dimensions		
mm/w/h/d	420 x 133 x 355	420 x 155 x 355
weight	16kg standard rod finish	19kg standard rod finish
note	with 4 leg integra finish the width is 480mm and 3mm is added in height. Each leg weighs 1 kg.	

Chord Electronics Limited
The Pumphouse
Farleigh Lane
East Farleigh
Kent ME16 9NB

Tel: +44 (0) 1622 721444

Fax: +44 (0) 1622 721555

Email: sales@chord.softnet.co.uk

Web: www.chordelectronics.co.uk