

welcome

Thank you for buying a Chord Electronics product.

Before you start to enjoy using your Chord Electronics product, please take a couple of minutes to read how to connect your audio equipment and loudspeakers to your Chord Choral product and how to maximise your listening experience.

user guide for

phono stage
SYMPHONIC

pre-amplifier

PRIMA

The pre-amplifier is the control centre of your system. By connecting your audio sources to it you can choose the source you want at any particular time and control it.

You can also adjust the balance and volume before the signal is sent to a power amplifier. Your pre-amplifiers can be operated manually or via any Chord remote control.

power amplifier

MEZZO

The power amplifier is the heart of your system, and your Chord amplifier offers stunning results providing effortless power across the whole spectrum of music's tonal span.

phono stage

SYMPHONIC

The phono stage provides the vital conditioning needed for a signal coming from the stylus of your turntable and hugely amplifies the signal before it is fed to your pre-amplifier. Combining high performance and ease of use, the phono stage is an important component in a system that utilises a turntable.

digital to analogue converter

DAC 64

This award winning, state of the art product converts the digital signal coming from your digital sources (such as a DVD/CD transport) into a suitable analogue signal that can be fed to your pre-amplifier.

background

We want you to be confident using your new Chord Electronics product.

You are probably an audiophile with extensive knowledge of audio equipment.

However, you may not be!

So in the following section we explain a few basics to help you get started, or get you back up to speed if you are a little rusty.

connecting your equipment

Chord amplifiers are supplied with and designed to be connected using balanced inputs. The interconnecting cables you use will depend on the available input and output sockets on your other equipment. We have installed unbalanced inputs on all Chord equipment, thus enabling you to mix Chord Electronics and other manufacturer's equipment.

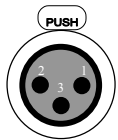

Balanced inputs carry twice the strength of signal of unbalanced inputs and are able to be fed down long lengths of cable with less deterioration of signal. They are also less prone to interference than unbalanced inputs. Balanced inputs have three pins and use Neutric XLR style connectors. Pin 1 is earth, pin 2 is positive and pin 3 is negative.



Unbalanced inputs use RCA phono connectors, which are gold plated with teflon high performance dielectric insulators for optimum performance.

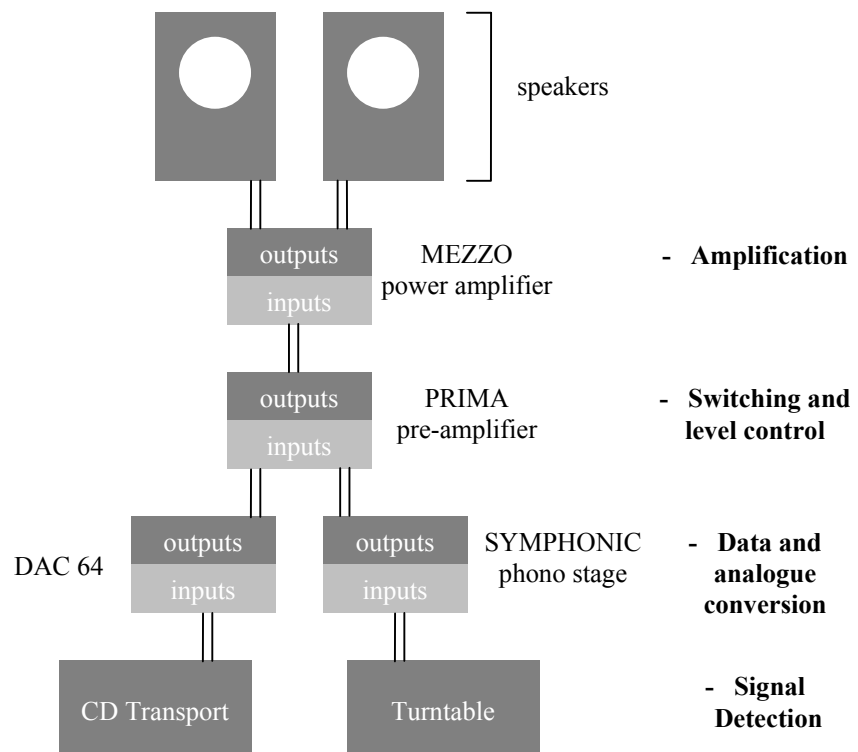

Basic system diagram

when setting up

To ensure that your Chord product works efficiently and safely, please pay particular attention to the following issues.

ventilation

Your Chord product should have at least 5cm of clear space all around it to ensure a free flow of air at all times. We do not recommend that you place your Chord product directly on a carpet as this can damage the equipment through blocked ventilation.

mains lead and plug

All Chord equipment comes supplied with the correct mains lead and plug. This should be used at all times.

if you need to fit a plug for UK/Europe

Connect the blue wire to the neutral terminal

Connect the brown wire to the live terminal

Connect the yellow/green wire to the earth terminal

if you need to fit a plug for US/Canada

Connect the white wire to the neutral terminal

Connect the black wire to the live terminal

Connect the green to the earth terminal

earthing issues in Europe

In some European countries a hum may occur if your processor is connected to mains sockets that do not have an earth. If this is the case please ensure that:

1. Your equipment is connected via a multi-way mains block which contains an earth point at each socket outlet. This is to ensure that the chassis metalwork of each item is connected together.
2. We recommend that an earthing method for your building is implemented.
3. Use the connecting points on your Chord unit and connect to an available earth point.

safety warnings

It is important that your equipment is earthed at all times via its own mains lead. Failure to do this may be hazardous. The power supply components within the units are designed to be operated at lethal voltages and energy levels. Circuit designs that embody these components conform with applicable safety requirements. Precautions must be taken to prevent accidental contact with power-line potentials. Do not connect grounded test equipment.

This unit complies with EN 50081-1 and IEC 801/2

mains connection

The mains connector of your Choral product is at the back of the unit. Plug the female end (socket) of the mains cable into the power connector of your Choral product, and the male end (plug) of the mains cable into mains wall socket or mains extension socket. The mains connector type will differ slightly for each Choral product. This is due to the highly compact nature of this range requiring differences in chassis metalwork for each product.

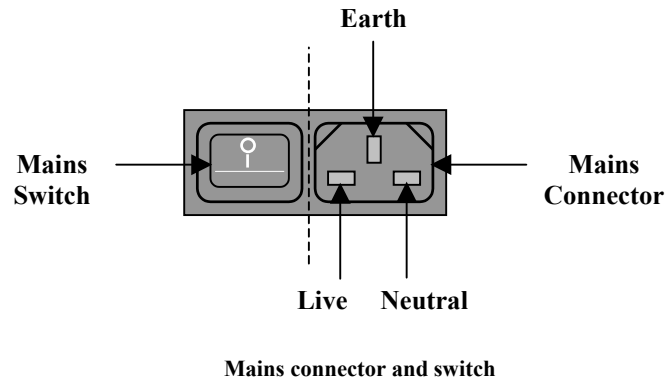

powering up

Press the bottom part of the power switch labelled 'I'.

powering down

Press the top part of the power switch labelled 'O'.

balanced outputs on the SYMPHONIC

You need to connect the outputs on the back of your SYMPHONIC to a pre-amplifier, which in turn will feed a signal to a power amplifier in order to drive your loudspeakers. There is a pair of balanced XLR outputs, which will drive a 68Ω load.

connecting to your pre-amplifier

Use the XLR style output connectors to connect your SYMPHONIC to the XLR style input connectors of your PRIMA or any other model of pre-amplifier. Ensure that you connect the left output on the SYMPHONIC to your left input on your pre-amplifier. Also the right output on the SYMPHONIC should be connected to the right input on your pre-amplifier.



Balanced outputs on the SYMPHONIC

unbalanced outputs on the SYMPHONIC

You need to connect the outputs on the back of your SYMPHONIC to a pre-amplifier, which in turn will feed a signal to a power amplifier in order to drive your loudspeakers. All Chord equipment is designed to be used with balanced connections to maximise audio signal quality. However there is also a pair of unbalanced outputs as well in case your pre-amplifier does not have balanced inputs.

connecting to your pre-amplifier

Use the phono style output connectors to connect your SYMPHONIC to the phono style input connectors of your pre-amplifier. Ensure that you connect the left output on the SYMPHONIC to your left input on your pre-amplifier. Also the right output on the SYMPHONIC should be connected to the right input on your pre-amplifier.

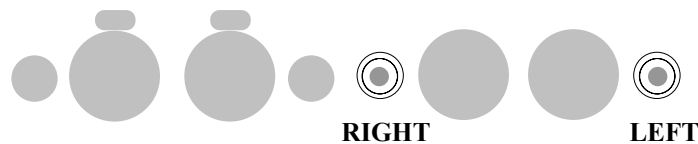

Unbalanced outputs on the SYMPHONIC

balanced inputs on the SYMPHONIC

You need to connect the outputs on your turntable inputs of your SYMPHONIC phono stage, which in turn will feed a signal to a pre-amplifier. The signal will then pass onto a power amplifier in order to drive your loudspeakers. There is a pair of balanced XLR inputs on your SYMPHONIC phono stage.

connecting to your phono stage

Use the XLR style input connectors to connect your SYMPHONIC to the XLR style output connectors of your turntable. Ensure that you connect the left output of your turntable to the left input on your SYMPHONIC. Also the right output on the turntable should be connected to the right input on your SYMPHONIC.

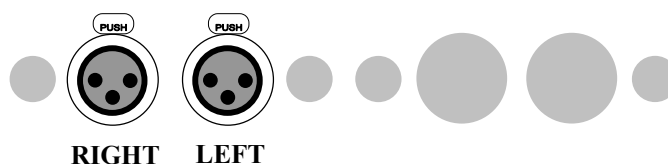

Balanced inputs on the SYMPHONIC

unbalanced inputs on the SYMPHONIC

You need to connect the outputs on your turntable inputs of your SYMPHONIC phono stage, which in turn will feed a signal to a pre-amplifier. The signal will then pass onto a power amplifier in order to drive your loudspeakers. All Chord equipment is designed to be used with balanced connections to maximise audio signal quality. However there is also a pair of unbalanced inputs as well in case your turntable does not have balanced outputs.

connecting to your turntable

Use the phono style input connectors to connect your SYMPHONIC to the phono style output connectors of your turntable. Ensure that you connect the left output of your turntable to the left input on your SYMPHONIC. Also the right output on the turntable should be connected to the right input on your SYMPHONIC.

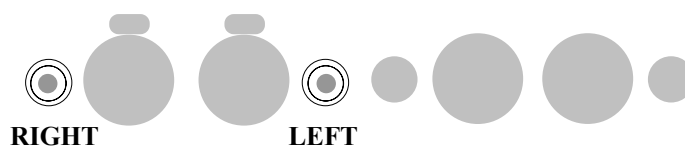

Unbalanced inputs on the SYMPHONIC

earthing connections on the SYMPHONIC

You need to ensure that the earth on your turntable and phono stage is correctly matched. It is important that the electronic circuitry in your turntable and phono stage are referencing to the same earth point in order to achieve the best possible sound quality for the playback of your vinyl recordings.

connecting the earth on your turntable to the SYMPHONIC

Use the earthing point on your SYMPHONIC to connect to the earth connection on your turntable. The earthing point is situated just above the right phono output on the SYMPHONIC phono stage.

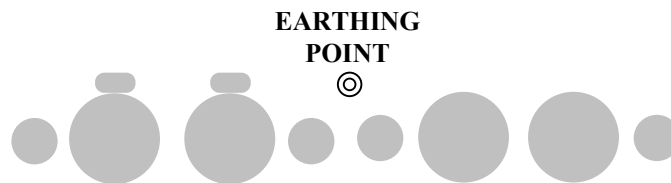

Earthing point on the SYMPHONIC

everyday use of the SYMPHONIC

Above the input and output connectors on the back of the SYMPHONIC are a set of 12 selector switches. These are used to select balanced or unbalanced inputs, set the input impedance, set the input gain and select an optional rumble filter.

using the rumble filter

The rumble filter is a form of Rausch filter. This is essentially a high pass filter that is used to remove certain low frequencies caused by turntable deck rumble whilst allowing all of the frequency content of the music being played through. To activate the rumble filter press the rumble filter switch in. To de-activate the rumble filter, simply press the rumble switch again to release the switch.



Rumble filter switch

selecting input gain

There are four selector switches to the left of the rumble filter selector switch that are used to set up the required input gain on the SYMPHONIC. The four input gain selection switches allow a choice between four values of input gain to be added into the input signal path. These multiple options are very useful when you are adjusting the input gain on the SYMPHONIC in order to match with the performance of the output stages of your turntable. To add a particular input gain into the signal path, press the appropriate switch in. To remove a selected input gain, simply press the switch again to release the switch.

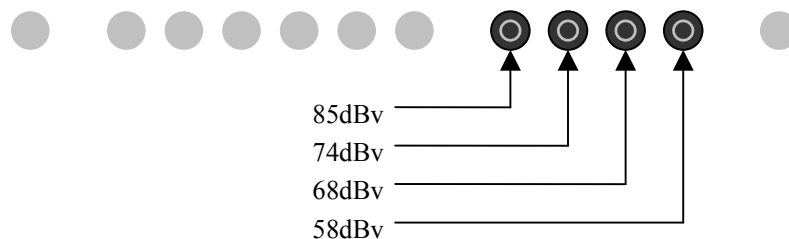

Input gain selection switches

selecting input impedance

There are six selector switches to the left of the input gain selector switches that are used to set up the required input impedance on the SYMPHONIC. Without using any additional impedance the SYMPHONIC features 50pF input impedance when using unbalanced inputs. If you are using balanced inputs then all impedance values are doubled. The six input impedance selection switches allow six values of impedance to be added into the input signal path. These multiple options are very useful when you are adjusting the input impedance on the SYMPHONIC in order to match with the performance of the output stages of your turntable. To add a particular input impedance into the signal path, press the appropriate switch in. To remove a selected input impedance, simply press the switch again to release the switch.

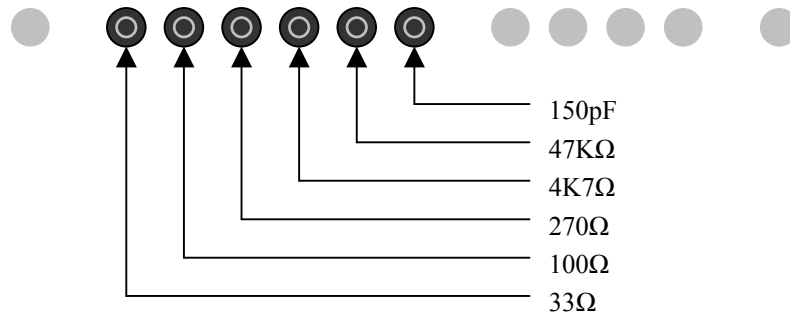

Input impedance selection switches

selecting balanced or unbalanced inputs

The selector switch that is situated furthest left is the balanced / unbalanced input selector switch. If you wish to use balanced input connections press this switch in. If you are using unbalanced input connections that this switch should be out.



Balanced / unbalanced input selection switch

settings on the SYMPHONIC

On the top panel of the aluminium chassis of the SYMPHONIC, there are two glass domes. Under the glass domes, there are LEDs that illuminate to show the current settings that are selected on the SYMPHONIC. For each setting that you make on the selector switches on the back of the SYMPHONIC, a pair of coloured LEDs will light on the boards below the glass domes on the top panel of the SYMPHONIC.

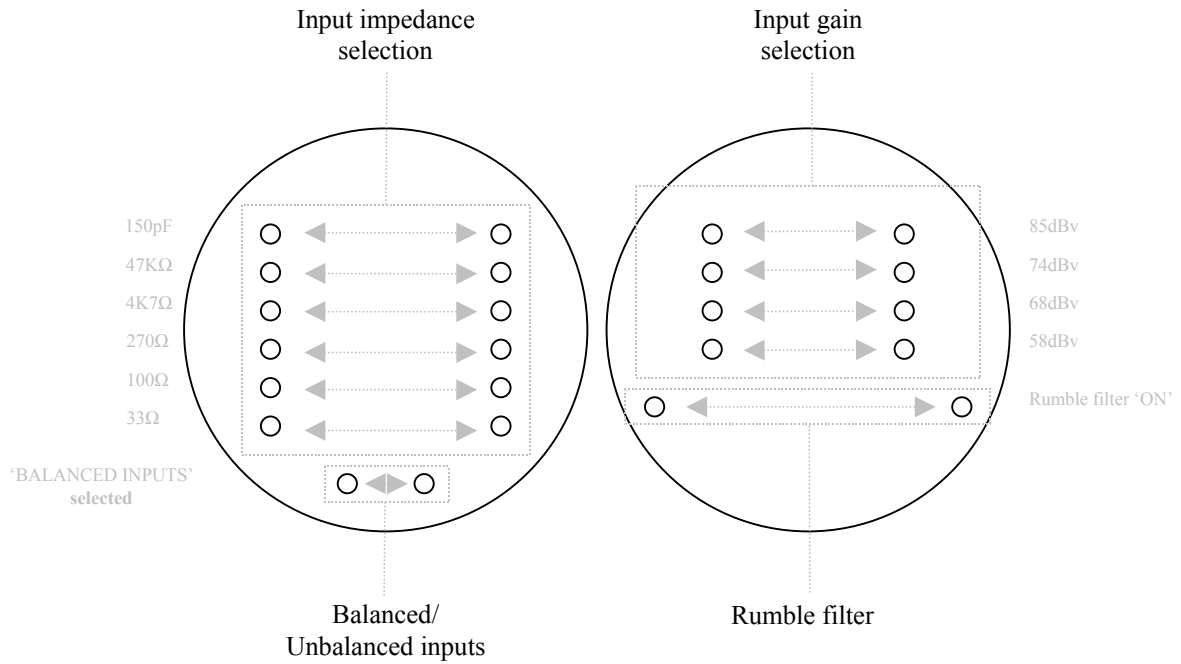

LEDs featured on the SYMPHONIC

maintenance of the SYMPHONIC

cleaning

To clean finger marks and other blemishes from your phono stage spray clear glass cleaner onto a soft lint free cloth and then use the cloth to gently clean your Chord product.

servicing

There are no user serviceable parts in your Chord product, and it should only be serviced by Chord Electronics Limited or their expressly approved Service Agents.

frequently asked questions about the SYMPHONIC

can I use any combination of impedance selections when matching the SYMPHONIC to my turntable?

Yes, the impedance selections provide a wide range of various impedance values in mixed combinations to offer greater versatility and to aid integration with a variety of different turntables.

what is RIAA equalisation and the RIAA curve?

RIAA equalisation is a special form of equalisation that is employed when creating vinyl recordings and cuts lower frequencies in the process. This is used to reduce wide grooves that are difficult for a turntable stylus to follow and also increases the recording time available on a vinyl disc. The RIAA curve is a set standard for frequency response of filters used when playing back vinyl recordings, used to restore lower frequencies that were reduced at the recording stage.

balanced connections are being used in my system and there are noticeable differences in the left and right channels.

Use the balanced input selection switch on the back of the SYMPHONIC by pressing the selector switch in to select balanced inputs.

why is there humming coming from the loudspeakers?

Check that you've earthed the SYMPHONIC to the turntable in your system. This will ensure that the circuitry inside your turntable and phono stage is using the same earth reference point.