

welcome

Thank you for buying a Chord Electronics product.

Before you start to enjoy using your Chord Electronics product, please take a couple of minutes to read how to connect your audio equipment and loudspeakers to your Chord Choral product and how to maximise your listening experience.

user guide for

power amplifier
MEZZO

pre-amplifier

PRIMA

The pre-amplifier is the control centre of your system. By connecting your audio sources to it you can choose the source you want at any particular time and control it.

You can also adjust the balance and volume before the signal is sent to a power amplifier. Your pre-amplifiers can be operated manually or via any Chord remote control.

power amplifier

MEZZO

The power amplifier is the heart of your system, and your Chord amplifier offers stunning results providing effortless power across the whole spectrum of music's tonal span.

phono stage

SYMPHONIC

The phono stage provides the vital conditioning needed for a signal coming from the stylus of your turntable and hugely amplifies the signal before it is fed to your pre-amplifier. Combining high performance and ease of use, the phono stage is an important component in a system that utilises a turntable.

digital to analogue converter

DAC 64

This award winning, state of the art product converts the digital signal coming from your digital sources (such as a DVD/CD transport) into a suitable analogue signal that can be fed to your pre-amplifier.

background

We want you to be confident using your new Chord Electronics product.

You are probably an audiophile with extensive knowledge of audio equipment.

However, you may not be!

So in the following section we explain a few basics to help you get started, or get you back up to speed if you are a little rusty.

connecting your equipment

Chord amplifiers are supplied with and designed to be connected using balanced inputs. The interconnecting cables you use will depend on the available input and output sockets on your other equipment. We have installed unbalanced inputs on all Chord equipment, thus enabling you to mix Chord Electronics and other manufacturer's equipment.

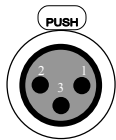

Balanced inputs carry twice the strength of signal of unbalanced inputs and are able to be fed down long lengths of cable with less deterioration of signal. They are also less prone to interference than unbalanced inputs. Balanced inputs have three pins and use Neutric XLR style connectors. Pin 1 is earth, pin 2 is positive and pin 3 is negative.



Unbalanced inputs use RCA phono connectors, which are gold plated with teflon high performance dielectric insulators for optimum performance.

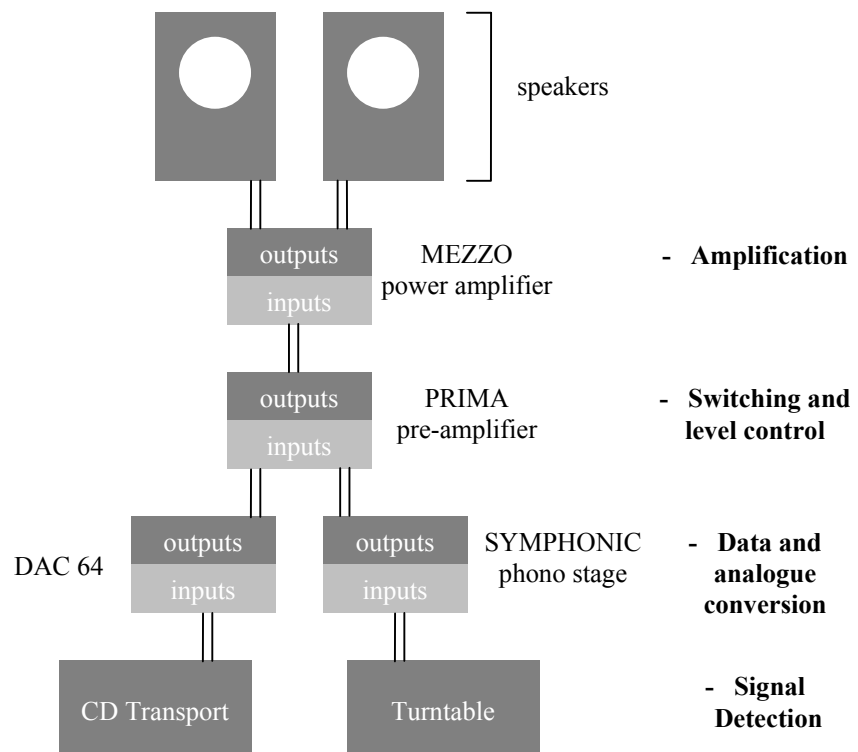

Basic system diagram

when setting up

To ensure that your Chord product works efficiently and safely, please pay particular attention to the following issues.

ventilation

Your Chord product should have at least 5cm of clear space all around it to ensure a free flow of air at all times. We do not recommend that you place your Chord product directly on a carpet as this can damage the equipment through blocked ventilation.

mains lead and plug

All Chord equipment comes supplied with the correct mains lead and plug. This should be used at all times.

if you need to fit a plug for UK/Europe

Connect the blue wire to the neutral terminal

Connect the brown wire to the live terminal

Connect the yellow/green wire to the earth terminal

if you need to fit a plug for US/Canada

Connect the white wire to the neutral terminal

Connect the black wire to the live terminal

Connect the green to the earth terminal

earthing issues in Europe

In some European countries a hum may occur if your processor is connected to mains sockets that do not have an earth. If this is the case please ensure that:

1. Your equipment is connected via a multi-way mains block which contains an earth point at each socket outlet. This is to ensure that the chassis metalwork of each item is connected together.
2. We recommend that an earthing method for your building is implemented.
3. Use the connecting points on your Chord unit and connect to an available earth point.

safety warnings

It is important that your equipment is earthed at all times via its own mains lead. Failure to do this may be hazardous. The power supply components within the units are designed to be operated at lethal voltages and energy levels. Circuit designs that embody these components conform with applicable safety requirements. Precautions must be taken to prevent accidental contact with power-line potentials. Do not connect grounded test equipment.

This unit complies with EN 50081-1 and IEC 801/2

mains connection

The mains connector of your Choral product is at the back of the unit. Plug the female end (socket) of the mains cable into the power connector of your Choral product, and the male end (plug) of the mains cable into mains wall socket or mains extension socket. The mains connector type will differ slightly for each Choral product. This is due to the highly compact nature of this range requiring differences in chassis metalwork for each product.

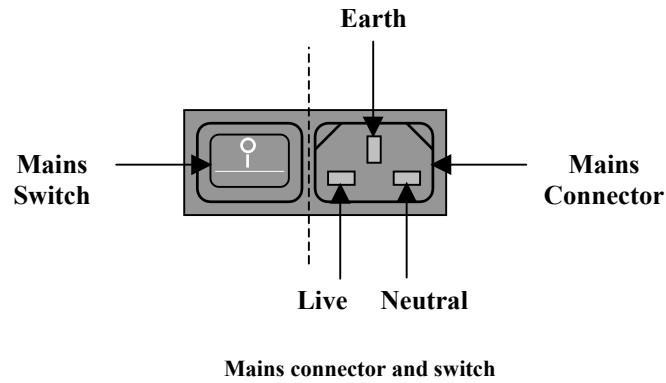

powering up

Press the bottom part of the power switch labelled 'I'.

powering down

Press the top part of the power switch labelled 'O'.

connecting your MEZZO

You need to connect the outputs from your pre-amplifier to your power amplifier and then connect your power amplifier to your loudspeakers. There are two pairs of inputs. You can connect to either the XLR or RCA outputs, but not to both types at the same time. All connections should be made with the power turned off.

connecting to your power amplifier using XLR style inputs

Use XLR style connectors to connect:

- ◆ the Right output from your pre-amplifier to the Right balanced input
- ◆ the Left output from your pre-amplifier to the Left balanced input.

connecting to your power amplifier using unbalanced RCA style inputs

Use RCA style connectors to connect:

- ◆ the Right output of your pre-amplifier to the Right input phono socket
- ◆ the Left output of your pre-amplifier to the Left input phono socket.

connecting your loudspeakers

Connect a pair of loudspeakers to the Left and Right outputs on the MEZZO. Each output on the MEZZO has a red and white connection that should be connected to colour matched terminals on your loudspeakers.

Note: The WBT rhodium plated 4mm speaker binding posts will accept 4mm banana plugs (WBT-0645 or WBT-0644) or 6mm spades (WBT-0680). Making connections using bare wire is not recommended.

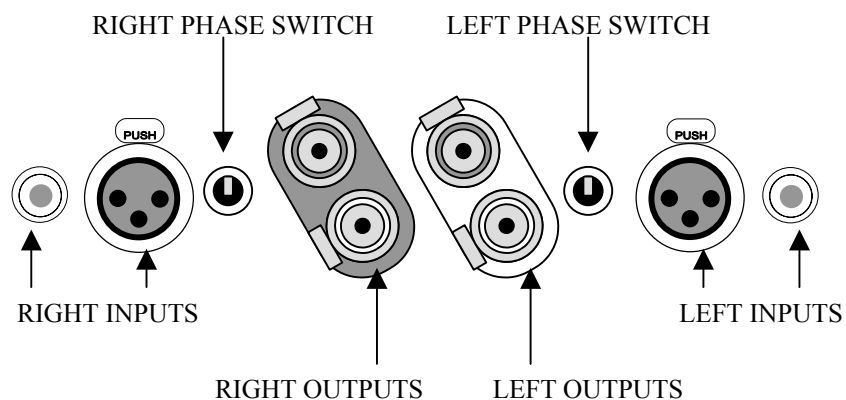

Connections on the MEZZO

bridged mono connections for your MEZZO

There are two main ways that your MEZZO can be connected to loudspeakers. One is the normal stereo configuration as assumed on the previous page. See page 11 for a diagram. The other way to connect your MEZZO to loudspeakers is the bridged mono configuration. See page 10 for a diagram.

bridged mono configuration using existing Chord pre-amplifiers other than the PRIMA

The bridged mono configuration allows two separate power amplifiers to be used in a system, each feeding a separate loudspeaker. In this manner, each power amplifier only carries the signal for the left or right channel of audio. This ensures that cross-talk distortion or interference that may normally occur between the left and right channels is completely eliminated. Please note that Chord equipment is designed to the highest possible standards available so if this bridged mono configuration is not adopted and a normal stereo configuration is used, you will still be experiencing audio quality of the highest standard.

Take two balanced outputs from the pre-amplifier on one channel only
I.e. output 1 left channel and output 2 left channel. Plug these into the balanced inputs on the first MEZZO. Switch the right channel phase switch to its up position and the left channel phase switch to its down position. Plug one loudspeaker across the red speaker terminals only (one red post is on the left output and one red post is on the right output). This will now be bridged.

Repeat the process with the second MEZZO for the right channel, making sure all the connections and switch settings are identical as for the left channel. Connect the output 1 right channel and output 2 right channel of the pre-amplifier to the balanced inputs of the second MEZZO. Again, switch the right channel phase switch to its up position and the left channel phase switch to its down position.. As before, connect the second loudspeaker across the red speaker terminals only.

bridging using the PRIMA pre-amplifier

If you are using a PRIMA pre-amplifier in your system, you need to bridge two MEZZO power amplifiers using two balanced Y leads as the Prima has only one balanced output. So you need to feed both channels of one MEZZO amplifier with the same signal i.e. either right or left. You only use the two red terminals when bridged. So Right Red (+) remains as is and Left Red (+) becomes Right return (-) or Black in the case of most speaker cables.

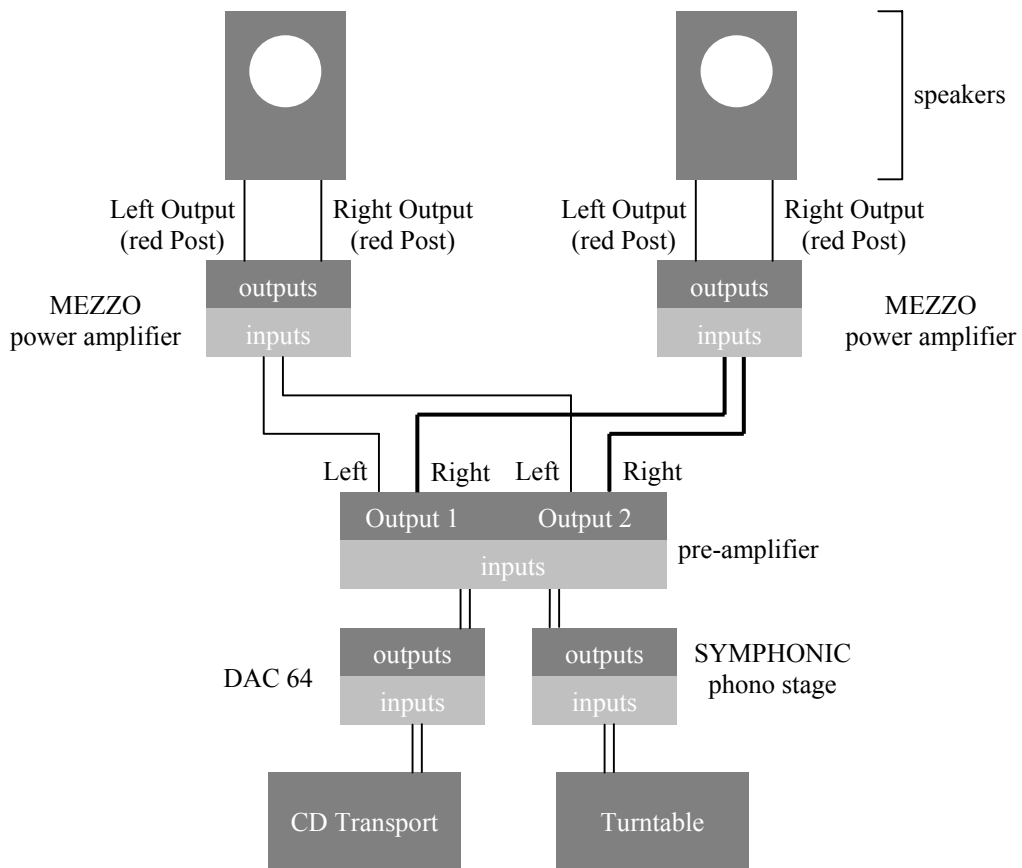

Bridged mono connections for the MEZZO

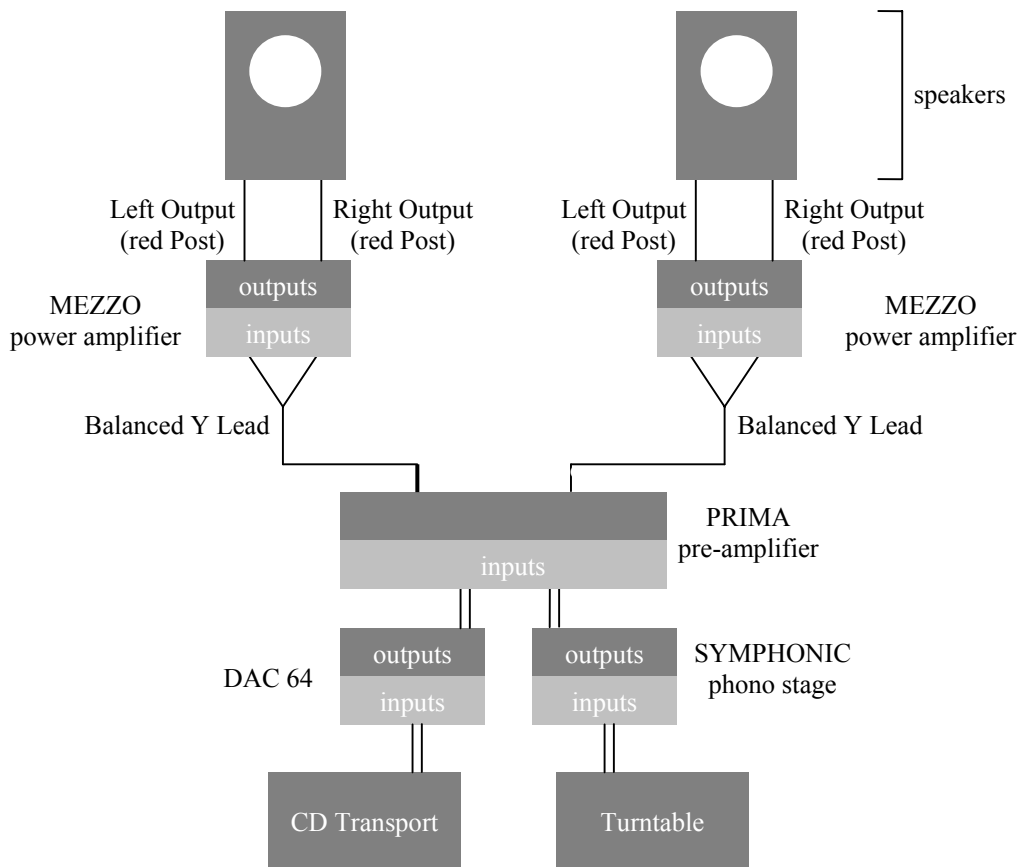

Bridged mono connections for the MEZZO using the PRIMA

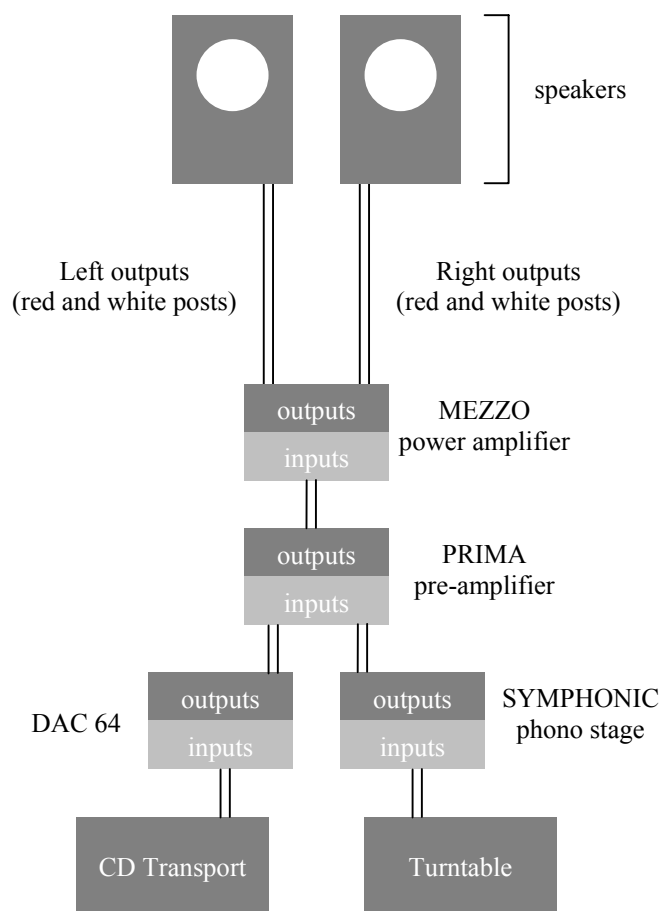

Normal stereo connections for the MEZZO

everyday use of the MEZZO

phase switching

You can choose the phase of the signals that are sent to your loudspeakers, to account for varying speaker configurations. There are two phase shift toggle switches on the MEZZO, one for each output. The diagram on the previous page shows these two switches. When the switches are in their UP position, the signals at the outputs is inverted by 180 degrees. When the switches are in their DOWN position, the signals at the outputs are non-inverted, with no phase shift.

automatic shutdown

1. If there is a major overload or short circuit the MEZZO will detect this and shut down automatically and the amplifier will go into 'bounce mode'. When in bounce mode, the visible interior of the MEZZO will flash with blue illumination. The MEZZO should then be switched off immediately at the mains.

2. When the fault has been rectified the power amplifier can be switched on and will power up as usual. You should wait at least two minutes before turning the amplifier on again at the mains to allow the power supply protection circuitry to reset itself.

maintenance of the MEZZO

cleaning

To clean finger marks and other blemishes from your amplifier spray clear glass cleaner onto a soft lint free cloth and then use the cloth to gently clean your amplifier.

servicing

There are no user serviceable parts in your Chord amplifier, and it should only be serviced by Chord Electronics Limited or their expressly approved Service Agents.

frequently asked questions about the MEZZO

the amplifier is on and the switches are on but there is no sound coming out

Have you pressed the correct output from your pre-amplifier?

the sound is vague and ill defined

Check that both loudspeakers are connected correctly (+ve to +ve or red to red, and -ve to -ve or white to white) on both sides.

there is a buzzing sound coming from the loudspeakers

The system may not be properly earthed or the interconnect cables may be running near to mains cables.

I have connected my 3-channel amplifier to my processor and the main left and right out of my AV processor in to my hi-fi, but there is very little sound coming out of the left and right speakers

Have you set the volume on your stereo pre-amplifier to the correct gain to match the other channels in the system?

the sound is vague and ill defined

Check that both phase switches are in the correct position for stereo or bridged mono use.

See page 9.