

# welcome

Thank you for buying a Chord Electronics product.

Before you start to enjoy using your Chord Electronics product, please take a couple of minutes to read how to connect your audio equipment and loudspeakers to your Chord Choral product and how to maximise your listening experience.

## user guide for

pre amplifier (pages 8-24)

PRIMA

power amplifier (pages 25-31)

MEZZO

phono stage (pages 32-41)

SYMPHONIC

digital to analogue converter (pages 42-48)

DAC 64

# pre-amplifier

PRIMA

The pre-amplifier is the control centre of your system. By connecting your audio sources to it you can choose the source you want at any particular time and control it.

You can also adjust the balance and volume before the signal is sent to a power amplifier. Your pre-amplifiers can be operated manually or via any Chord remote control.

# power amplifier

MEZZO

The power amplifier is the heart of your system, and your Chord amplifier offers stunning results providing effortless power across the whole spectrum of music's tonal span.

# phono stage

SYMPHONIC

The phono stage provides the vital conditioning needed for a signal coming from the stylus of your turntable and hugely amplifies the signal before it is fed to your pre-amplifier. Combining high performance and ease of use, the phono stage is an important component in a system that utilises a turntable.

# digital to analogue converter

DAC 64

This award winning, state of the art product converts the digital signal coming from your digital sources (such as a DVD/CD transport) into a suitable analogue signal that can be fed to your pre-amplifier.

# background

We want you to be confident using your new Chord Electronics product.

You are probably an audiophile with extensive knowledge of audio equipment.

However, you may not be!

So in the following section we explain a few basics to help you get started, or get you back up to speed if you are a little rusty.

# connecting your equipment

Chord amplifiers are supplied with and designed to be connected using balanced inputs. The interconnecting cables you use will depend on the available input and output sockets on your other equipment. We have installed unbalanced inputs on all Chord equipment, thus enabling you to mix Chord Electronics and other manufacturer's equipment.

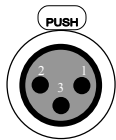

Balanced inputs carry twice the strength of signal of unbalanced inputs and are able to be fed down long lengths of cable with less deterioration of signal. They are also less prone to interference than unbalanced inputs. Balanced inputs have three pins and use Neutric XLR style connectors. Pin 1 is earth, pin 2 is positive and pin 3 is negative.



Unbalanced inputs use RCA phono connectors, which are gold plated with teflon high performance dielectric insulators for optimum performance.

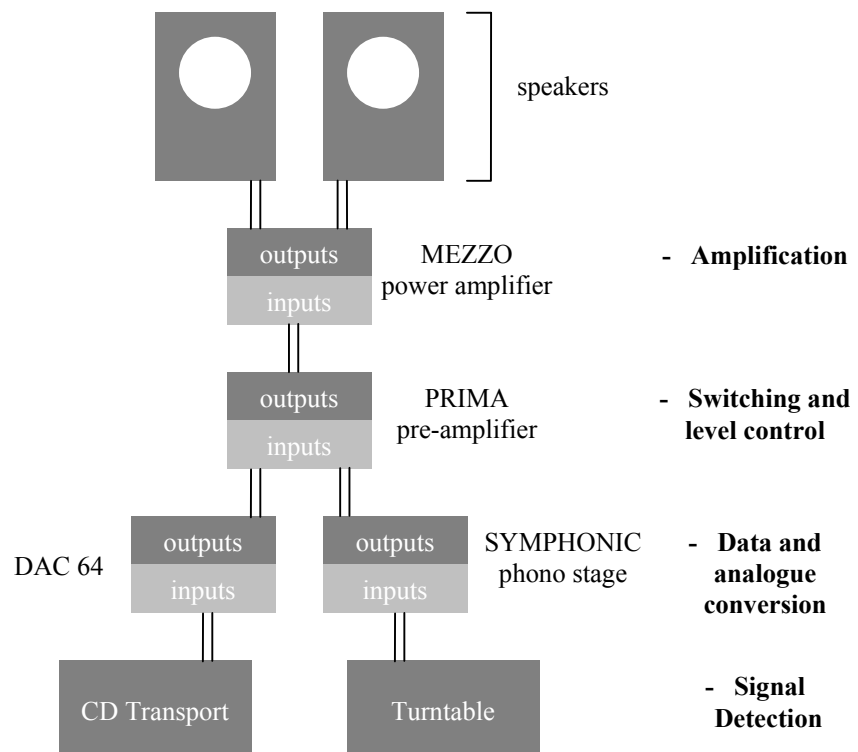

**Basic system diagram**

# when setting up

To ensure that your Chord product works efficiently and safely, please pay particular attention to the following issues.

## **ventilation**

Your Chord product should have at least 5cm of clear space all around it to ensure a free flow of air at all times. We do not recommend that you place your Chord product directly on a carpet as this can damage the equipment through blocked ventilation.

## **mains lead and plug**

All Chord equipment comes supplied with the correct mains lead and plug. This should be used at all times.

## **if you need to fit a plug for UK/Europe**

Connect the blue wire to the neutral terminal

Connect the brown wire to the live terminal

Connect the yellow/green wire to the earth terminal

## **if you need to fit a plug for US/Canada**

Connect the white wire to the neutral terminal

Connect the black wire to the live terminal

Connect the green to the earth terminal

## **earthing issues in Europe**

In some European countries a hum may occur if your processor is connected to mains sockets that do not have an earth. If this is the case please ensure that:

1. Your equipment is connected via a multi-way mains block which contains an earth point at each socket outlet. This is to ensure that the chassis metalwork of each item is connected together.
2. We recommend that an earthing method for your building is implemented.
3. Use the connecting points on your Chord unit and connect to an available earth point.

**safety warnings**

It is important that your equipment is earthed at all times via its own mains lead. Failure to do this may be hazardous. The power supply components within the units are designed to be operated at lethal voltages and energy levels. Circuit designs that embody these components conform with applicable safety requirements. Precautions must be taken to prevent accidental contact with power-line potentials. Do not connect grounded test equipment.

These unit comply with EN 50081-1 and IEC 801/2

# mains connection

The mains connector of your Choral product is at the back of the unit. Plug the female end (socket) of the mains cable into the power connector of your Choral product, and the male end (plug) of the mains cable into mains wall socket or mains extension socket. The mains connector type will differ slightly for each Choral product. This is due to the highly compact nature of this range requiring differences in chassis metalwork for each product.

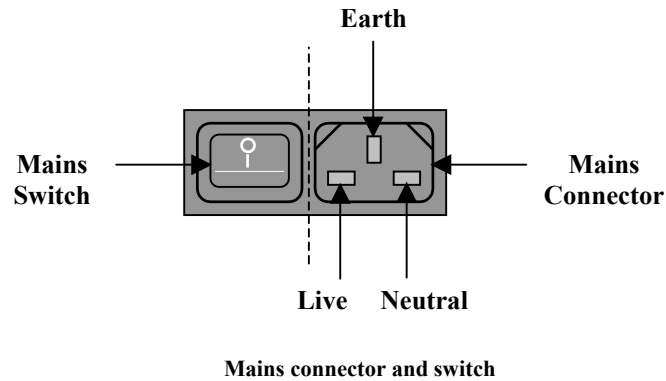

# powering up

Press the bottom part of the power switch labelled 'I'.

# powering down

Press the top part of the power switch labelled 'O'.

# outputs on the PRIMA

You need to connect the outputs on the back of your pre-amplifier to a power amplifier in order to drive your loudspeakers. There is a pair of balanced XLR outputs, which will drive a 68Ω load.

## connecting to your power amplifier

1. Use the XLR style output connectors to connect your PRIMA pre-amplifier to the XLR style input connectors of your power amplifier.
2. If you are using the PRE AMP REMOTE, then press the button marked **O/P 1**.
3. If you are using the Chord touch-screen remote control then press the **OUTPUT 1** LCD touch pad, which is on page 3 of the **CHORAL SERIES** device menu.



**Main outputs on the PRIMA**

# balanced inputs on the PRIMA

You can connect up to five items of source input equipment, such as CD player, Video, Tuner etc. to the inputs on your pre-amplifier.

## connecting to your source input equipment using balanced connections

1. Use the XLR style input connectors to connect your PRIMA pre-amplifier to the XLR style output connectors of your source input equipment.
2. If you are using the **PRE AMP REMOTE**, then press the button marked **1** that is grouped with main line bus buttons. The main bus buttons are grouped with the button marked **M**.
3. If you are using the Chord touch-screen remote control then press the **MAIN LINE 1** LCD touch pad, which is on page 1 of the **CHORAL SERIES** device menu.

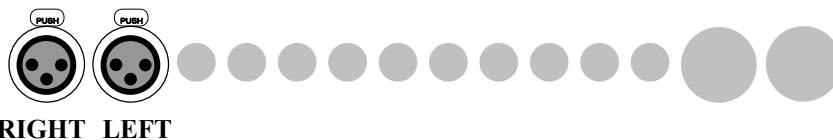

## Balanced inputs on the PRIMA – LINE 1

# unbalanced inputs on the PRIMA

## connecting to your source input equipment using unbalanced connections

There are 4 pairs of unbalanced phono input connections on the PRIMA. These are shown in the diagrams below.

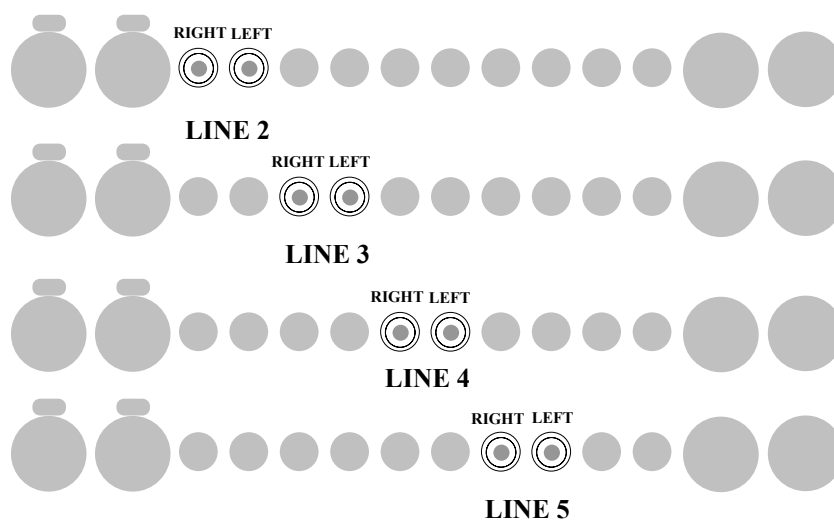

## Unbalanced inputs on the PRIMA

1. Use any of the four pairs of phono style input connectors to connect your PRIMA pre-amplifier to the phono style output connectors of your source input equipment.
2. If you are using the PRE-AMP REMOTE, then press the appropriate button marked either: **2**, **3**, **4** or **5** that is grouped with main line bus buttons, depending on the line input connectors that you have used. The main bus buttons are grouped with the button marked **M**.
3. If you are using the Chord touch-screen remote control then press the appropriate LCD touch pad, which are on page 1 of the **CHORAL SERIES** device menu.  
Use **MAIN LINE 2** for the LINE 2 input connectors.  
Use **MAIN LINE 3** for the LINE 3 input connectors.  
Use **MAIN LINE 4** for the LINE 4 input connectors.  
Use **MAIN LINE 5** for the LINE 5 input connectors.

# tape recording using the PRIMA

You can use the PRIMA to tape record the signal from an input source whilst you are listening to your main signal from another input source through the main outputs.

## connecting to a tape recorder to tape an audio source

use the pair of phono style connectors that are furthest to the right, next to the XLR style output connectors.



## Tape line outputs

### assigning an input source line to the tape line output

1. If you are using the **PRE AMP REMOTE**, press the corresponding numbered button, for the desired line input. Use the numbered buttons that are grouped with the button marked **T**.
2. If you are using the Chord touch-screen remote control, use the corresponding LCD touch pad that relates to the line input that you are using. These LCD touch pads are found on page 2 of the **CHORAL SERIES** menu and are labelled **TAPE LINE 1**, **TAPE LINE 2**, **TAPE LINE 3**, **TAPE LINE 4** and **TAPE LINE 5**.

# everyday use of the PRIMA

## controls on the PRIMA

The diagram below shows the controls on the PRIMA

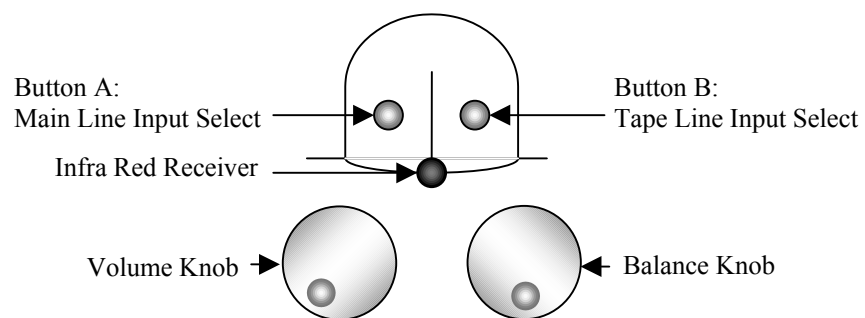

**Controls on the PRIMA**

**assigning an input to the main line outputs**

Your PRIMA uses the main line by default and the display will read:



To assign the main output with a particular input signal, press the button A several times to cycle through the 5 line inputs until, the one you wish to use is displayed. The options are shown in the diagram below:

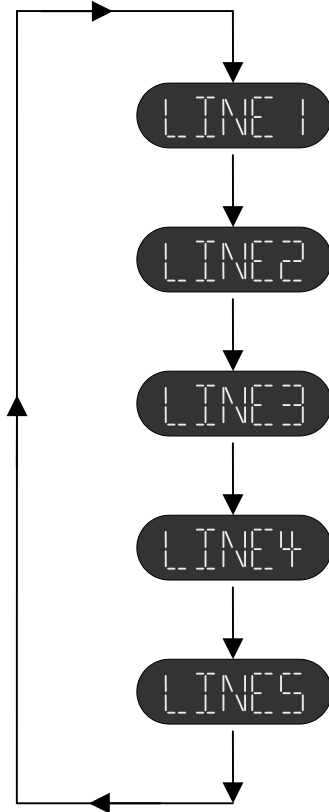

**Cycle of input selection options for the main line outputs**

**assigning an input to the tape line outputs**

To assign the tape line output with a particular input signal, press the button B several times to cycle through the 5 line inputs until, the one you wish to use is displayed. The options are shown in the diagram below:

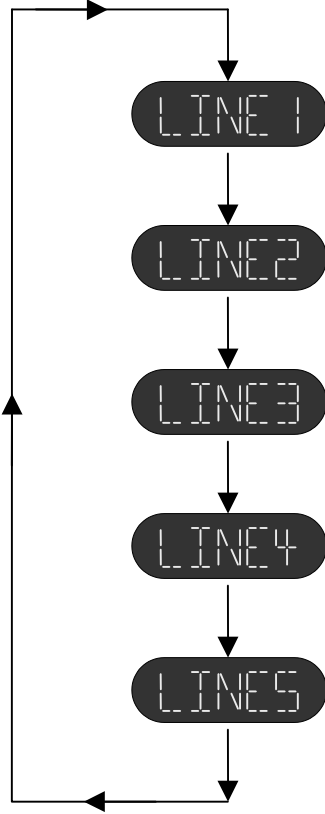

**Cycle of input selection options for the tape line outputs**

**viewing the settings for the main line**

To view the settings for the main line press and hold button A for two seconds. The first information that is shown is the current gain setting for the input line that is assigned to the main line output. The PRIMA stores the gain setting for each input line. There are six gain settings available in total that can be assigned to each input line and these are shown below. After the gain setting has been shown for a second, the input line that is currently assigned to the main line is displayed.

**viewing the settings for the tape line**

To view the settings for the tape line press and hold button B for two seconds. The first information that is shown is the current gain setting for the input line that is assigned to the tape line output. The PRIMA stores the gain setting for each input line. There are six gain settings available in total that can be assigned to each input line and these are shown below. After the gain setting has been shown for a second, the input line that is currently assigned to the tape line is displayed. When you are viewing the tape line settings, the display will indicate it is the tape line settings you are viewing using the letters 'TP'. The number of the input line that is assigned to the tape line is also shown. The diagrams below show the possible display settings for each input that can be set to the tape line outputs.



**Input lines that can be assigned to the tape line outputs**

**listening to the input assigned to the tape line**

If you wish to listen to the input that you have assigned to the tape line, you must assign the same input to the main line outputs using button A.

**adjusting the volume**

Use the volume knob to adjust the volume manually. A clockwise turn of the knob will increase the volume and an anti-clockwise turn of the knob will decrease the volume. The volume range runs from 0 to 98 and is displayed on the PRIMA as you alter the volume. If the outputs are muted, a volume change will un-mute the outputs to prevent large changes in volume from damaging your loudspeakers. The volume level is shown on the display as the word VOL and a two digit level as shown in the example diagram below.



**Volume display**

**changing the balance**

Use the balance knob to shift the balance between the left and right loudspeaker. A clockwise turn of the knob will shift the balance to the right speaker and an anti-clockwise turn of the knob will shift the balance to the left speaker. The centre of the balance control knob is at the lowest position of rotation, this is for product styling.

# using the PRE-AMP remote control with the PRIMA

Your PRE AMP remote control is a universal controller for all existing Chord pre-amplifiers and integrated amplifiers. For optimum use hold your control flat and point it directly at your integrated/pre amplifier.

## **selecting your input source**

press one buttons marked **1**, **2**, **3**, **4** or **5** of the main line controls as shown on page 18.

## **adjusting the volume**

1. Press the volume control marked ▲ to increase the volume.
2. Press ▼ to decrease the volume. The volume chosen will be shown on the digital display with figures from 0 to 98.

## **changing the balance**

1. Press the balance button marked ► to move the balance towards the right.
2. Press ◀ to move the balance to the left. The direction you are moving the balance towards will be displayed on the digital display.

## **mute**

1. Press the button marked **MUTE** to mute the amplifier.

## **to unmute**

1. Press the button marked **MUTE** again to unmute or
2. Press one of the volume buttons marked ▲ or ▼ or
3. Turn the volume knob on your amplifier up or down or
4. Press one of the buttons marked **O/P1** or **O/P1+2**.

## **input gain control**

See page 21

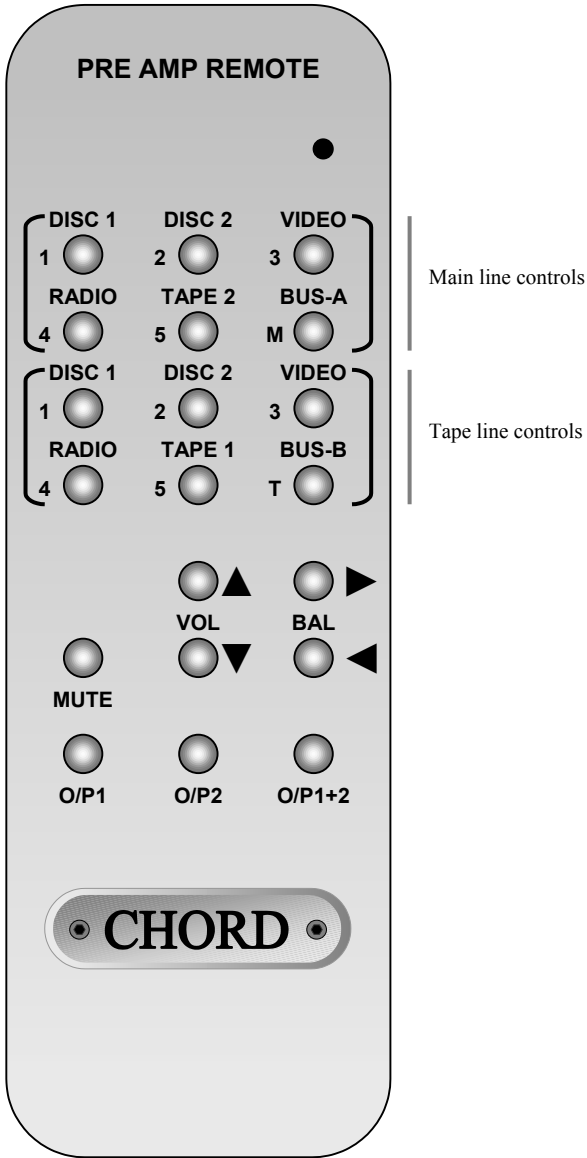

**PRE AMP REMOTE layout diagram**

# using the Chord touch-screen remote control with the PRIMA

The Chord touch screen remote control comes supplied with its own user manual, which describes in full how to use it and how to navigate its menus. The touch screen LCD touch pads allow control over the assignment of input signals to the main line and tape line. Volume, gain adjustment and muting are achieved using the mechanical buttons whilst you are in the menu for the Choral series.

## **entering the Choral series menu of the touch screen remote**

1. To turn on the remote press any of the mechanical buttons
2. Navigate the main menu of the remote by using the large LCD touch pads that show arrows until the **CHORAL SERIES** LCD touch pad is shown.
3. Press the **CHORAL SERIES** LCD touch pad to enter page 1 of the Choral series menu.

## **using the LCD touch pad controls to select an input**

1. Use the large LCD touch pads with arrows on them to change between the pages of the Choral series menu
2. Page 1 of the menu contains controls to assign inputs to the main line. There are five inputs to choose from: **MAIN LINE 1**, **MAIN LINE 2**, **MAIN LINE 3**, **MAIN LINE 4** and **MAIN LINE 5**. Pressing the **MAIN LINE LISTEN** LCD touch pad will allow you to view the settings for the main line.
3. Page 2 of the menu contains controls to assign inputs to the tape line. There are five inputs to choose from: **TAPE LINE 1**, **TAPE LINE 2**, **TAPE LINE 3**, **TAPE LINE 4** and **TAPE LINE 5**. Pressing the **TAPE LINE LISTEN** LCD touch pad will allow you to view the settings for the main line. To actually listen to the input line you are taping, you will need to assign the same input line number to the main line.

## **adjusting the volume**

1. Press the mechanical button marked **VOL+▶** to increase the volume.
2. Press the mechanical button marked **◀VOL-** to decrease the volume. The volume chosen will be shown on the digital display with figures from 0 to 98.

## **changing the balance**

1. Press the mechanical button marked **▲CH+** to move the balance towards the right.
2. Press the mechanical button marked **CH-▼** to move the balance to the left. The direction you are moving the balance towards will be displayed on the digital display.

## **mute**

1. Press the mechanical button marked **mute**.

**to unmute**

1. Press **mute** again to unmute or
2. Press the volume mechanical buttons up or down or
3. Turn the volume knob on your amplifier up or down or
4. Press the **OUTPUT 1** LCD touch pad on page 3 of the choral series menu.

Input gain control

See Page 21

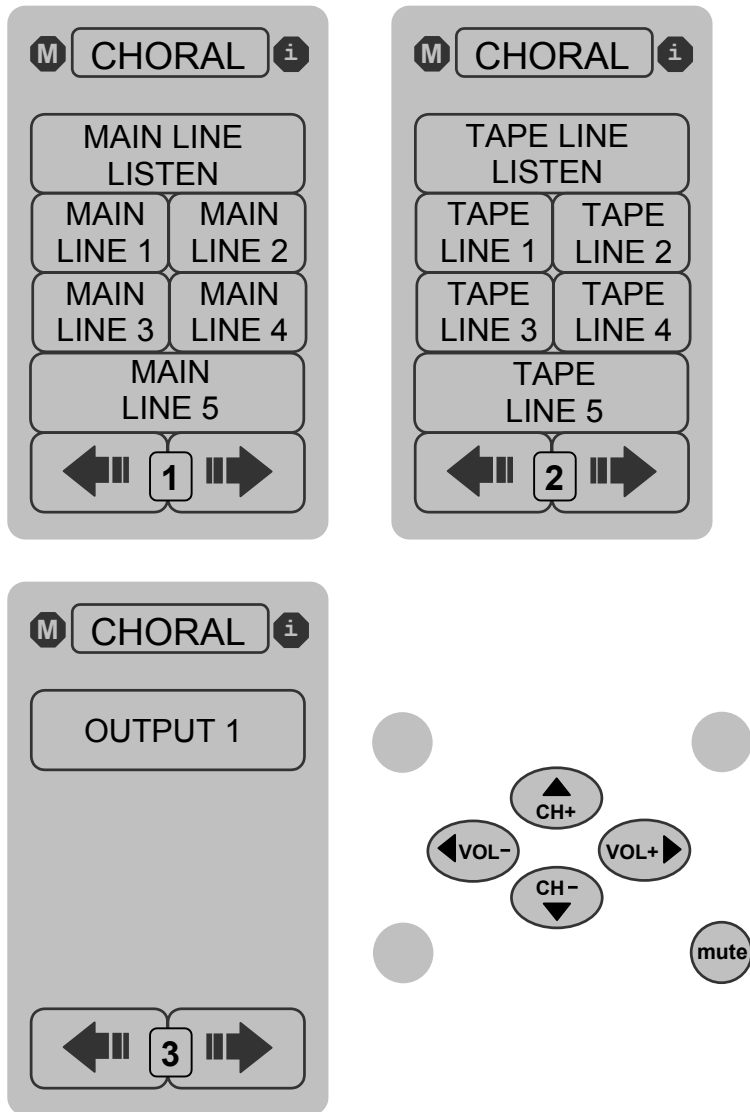

**LCD Touch Pads and mechanical buttons in the menu for the PRIMA**

# input gain control on the PRIMA

You can adjust the input gain on your input devices so that you can align the volume levels of your different inputs. There are six settings, which are x0.25, x0.50, x0.75, x1.00, x1.25 and x1.50.

Most modern input devices such as CD players have an unbalanced output voltage of 2V and a balanced output 4V, which does not require any increased gain amplification. In fact, to increase the gain on such an output level can lead to distortion of the signal.

However, older audio equipment may have an output voltage of less than 2V, in which case you may like to adjust the input gain.

## **increasing the input gain of the input assigned to the main line**

1. Press **M** on the pre amp remote followed by the **VOL** button marked **▲** or
2. Press the **MAIN LINE LISTEN** LCD touch pad on the Chord touch screen remote followed by the mechanical button marked **VOL+▶**.
3. Each time you carry out steps 1 or 2, the input gain assignment will be stepped up through the available settings.

## **reducing the input gain of the input assigned to the main line**

1. Press **M** on the pre amp remote followed by the **VOL** button marked **▼** or
2. Press the **MAIN LINE LISTEN** LCD touch pad on the Chord touch screen remote followed by the mechanical button marked **◀VOL-**.
3. Each time you carry out steps 1 or 2, the input gain assignment will be stepped down through the available settings.

## **increasing the input gain of the input assigned to the tape line**

1. Press **T** on the pre amp remote followed by the **VOL** button marked **▲** or
2. Press the **TAPE LINE LISTEN** LCD touch pad on the Chord touch screen remote followed by the mechanical button marked **VOL+▶**.
3. Each time you carry out steps 1 or 2, the input gain assignment will be stepped up through the available settings.

## **reducing the input gain of the input assigned to the tape line**

1. Press **T** on the pre amp remote followed by the **VOL** button marked **▼** or
2. Press the **TAPE LINE LISTEN** LCD touch pad on the Chord touch screen remote followed by the mechanical button marked **◀VOL-**.
3. Each time you carry out steps 1 or 2, the input gain assignment will be stepped down through the available settings.

**gain settings**

Once you have adjusted the gain setting on an input device your amplifier will remember the setting, even if it is switched off for many months. The six available gain settings are shown below as they are displayed on the PRIMA.



**Gain settings as displayed**

# maintenance of the PRIMA

## **adjusting the settings**

Always remember to make any changes to settings with the volume set low or an instant burst of sound could damage your loudspeakers

## **cleaning**

To clean finger marks and other blemishes from your amplifier spray clear glass cleaner onto a soft lint free cloth and then use the cloth to gently clean your amplifier.

## **changing the batteries in the PRE AMP REMOTE**

Simply undo the four small cross head screws on the side of your remote control. You may need to run a sharp knife along the join to remove the battery casing, then replace with four new AAA batteries as shown inside the battery compartment.

## **servicing**

There are no user serviceable parts in your Chord amplifier, and it should only be serviced by Chord Electronics Limited or their expressly approved Service Agents.

# frequently asked questions about the PRIMA

## **I've connected all the wires up but I can't hear any sound?**

Ensure that you've selected the correct input line for your connections.

## **why is there no display when I've turned the amplifier back on?**

You need to wait for two minutes after switching the unit off before switching it on again.

## **why is there humming coming from the loudspeakers?**

Check that you've earthed the unit. The interconnects need to be properly screened and placed away from mains cables. Using balanced inputs and outputs instead of RCA phono types can reduce interference.

## **the sound coming from the loudspeakers is distorted**

Check that the speakers are connected properly. It may be that the volume is turned up too high for your speakers or that you have set the gain for the input device too high.

Note:- if you are using the Chord DAC 64 converter always set the gain to 0.5

## **the amplifier was in standby mode and has turned itself off**

Changing connections while the amplifier is on, for example, dropping the stylus onto a record can cause the unit to shutdown. Check that the speaker cables have no stray inner core wires touching each other and bridging across speaker terminals, as this can cause a short circuit.

# connecting your MEZZO

You need to connect the outputs from your pre-amplifier to your power amplifier and then connect your power amplifier to your loudspeakers. There are two pairs of inputs. You can connect to either the XLR or RCA outputs, but not to both types at the same time. All connections should be made with the power turned off.

## connecting to your power amplifier using XLR style inputs

Use XLR style connectors to connect:

- ◆ the Right output from your pre-amplifier to the Right balanced input
- ◆ the Left output from your pre-amplifier to the Left balanced input.

## connecting to your power amplifier using unbalanced RCA style inputs

Use RCA style connectors to connect:

- ◆ the Right output of your pre-amplifier to the Right input phono socket
- ◆ the Left output of your pre-amplifier to the Left input phono socket.

## connecting your loudspeakers

Connect a pair of loudspeakers to the Left and Right outputs on the MEZZO. Each output on the MEZZO has a red and white connection that should be connected to colour matched terminals on your loudspeakers.

Note: The WBT rhodium plated 4mm speaker binding posts will accept 4mm banana plugs (WBT-0645 or WBT-0644) or 6mm spades (WBT-0680). Making connections using bare wire is not recommended.

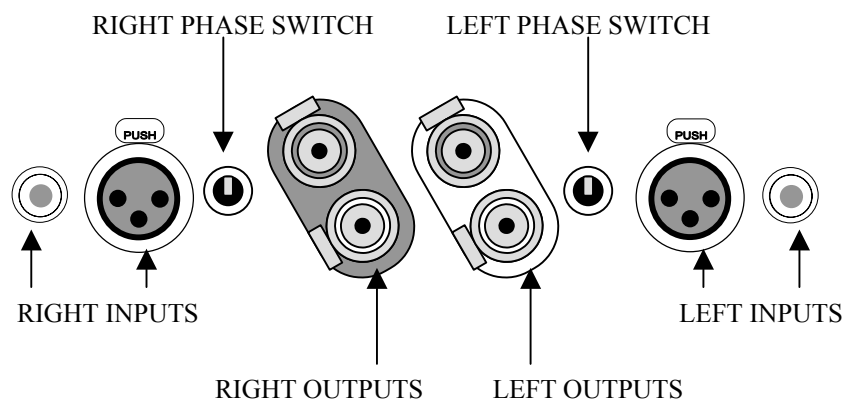

**Connections on the MEZZO**

# bridged mono connections for your MEZZO

There are two main ways that your MEZZO can be connected to loudspeakers. One is the normal stereo configuration as assumed on the previous page. See page 11 for a diagram. The other way to connect your MEZZO to loudspeakers is the bridged mono configuration. See page 10 for a diagram.

## **bridged mono configuration using existing Chord pre-amplifiers other than the PRIMA**

The bridged mono configuration allows two separate power amplifiers to be used in a system, each feeding a separate loudspeaker. In this manner, each power amplifier only carries the signal for the left or right channel of audio. This ensures that cross-talk distortion or interference that may normally occur between the left and right channels is completely eliminated. Please note that Chord equipment is designed to the highest possible standards available so if this bridged mono configuration is not adopted and a normal stereo configuration is used, you will still be experiencing audio quality of the highest standard.

Take two balanced outputs from the pre-amplifier on one channel only  
I.e. output 1 left channel and output 2 left channel. Plug these into the balanced inputs on the first MEZZO. Switch the right channel phase switch to its up position and the left channel phase switch to its down position. Plug one loudspeaker across the red speaker terminals only (one red post is on the left output and one red post is on the right output). This will now be bridged.

Repeat the process with the second MEZZO for the right channel, making sure all the connections and switch settings are identical as for the left channel. Connect the output 1 right channel and output 2 right channel of the pre-amplifier to the balanced inputs of the second MEZZO. Again, switch the right channel phase switch to its up position and the left channel phase switch to its down position.. As before, connect the second loudspeaker across the red speaker terminals only.

## **bridging using the PRIMA pre-amplifier**

If you are using a PRIMA pre-amplifier in your system, you need to bridge two MEZZO power amplifiers using two balanced Y leads as the Prima has only one balanced output. So you need to feed both channels of one MEZZO amplifier with the same signal i.e. either right or left. You only use the two red terminals when bridged. So Right Red (+) remains as is and Left Red (+) becomes Right return (-) or Black in the case of most speaker cables.

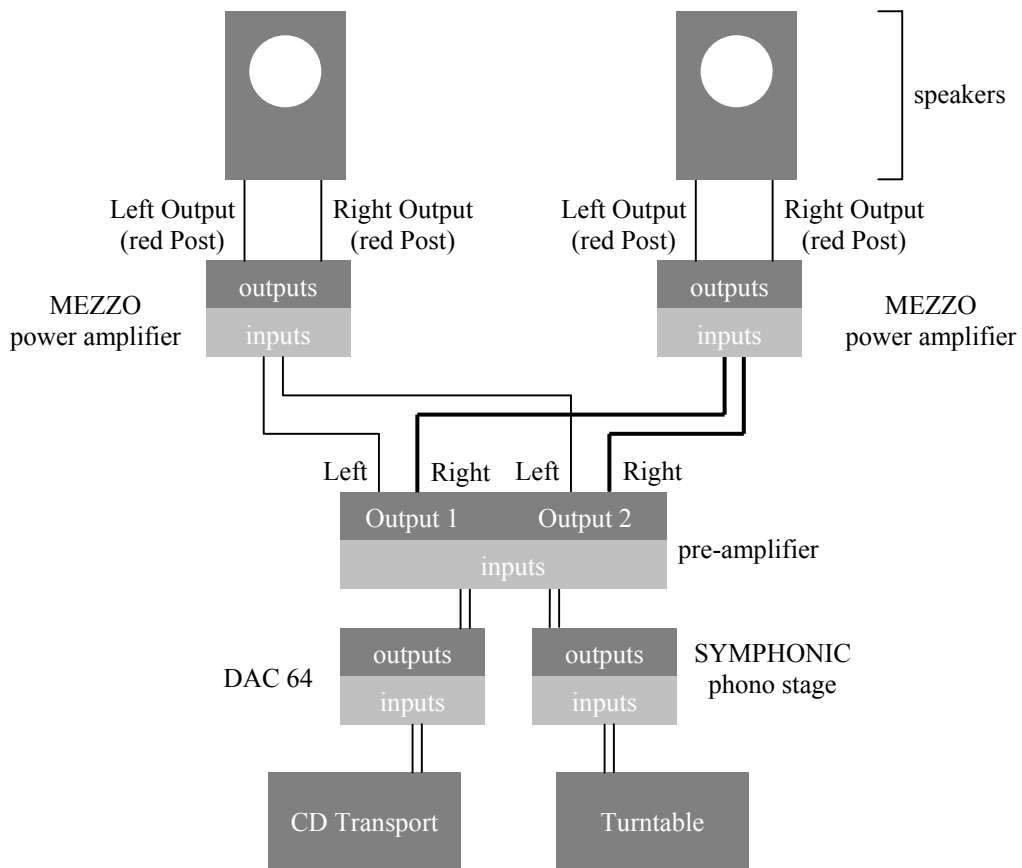

**Bridged mono connections for the MEZZO**

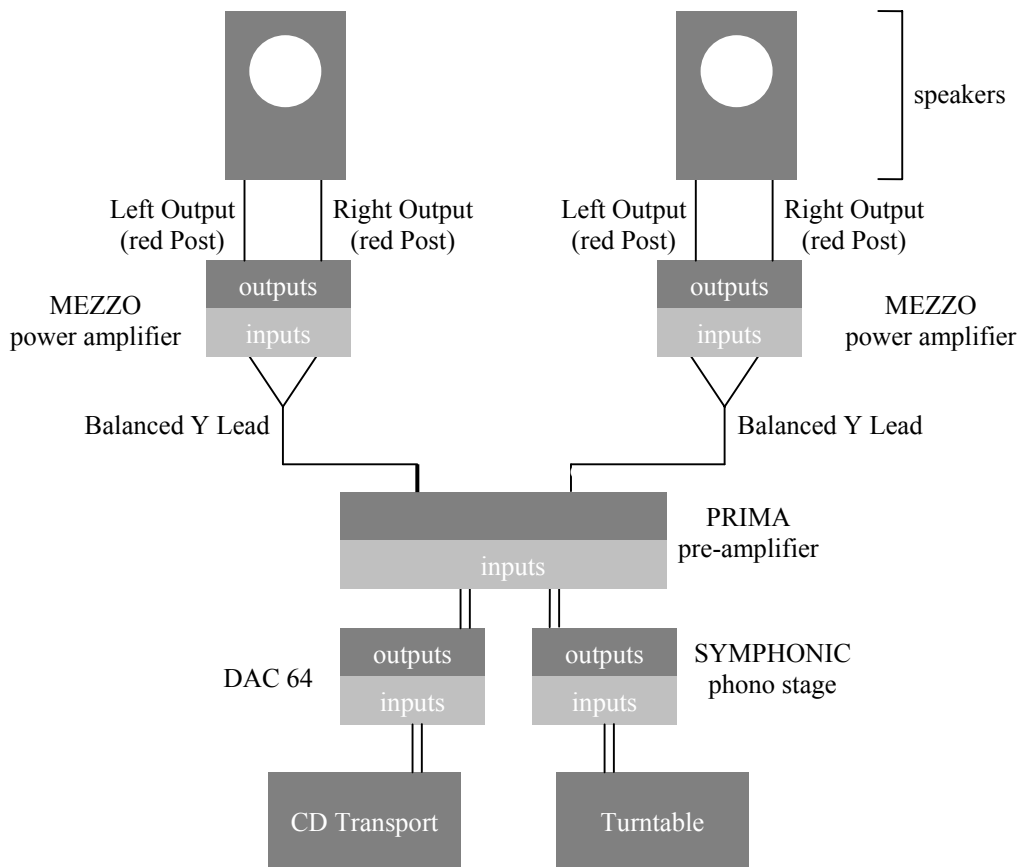

**Bridged mono connections for the MEZZO using the PRIMA**

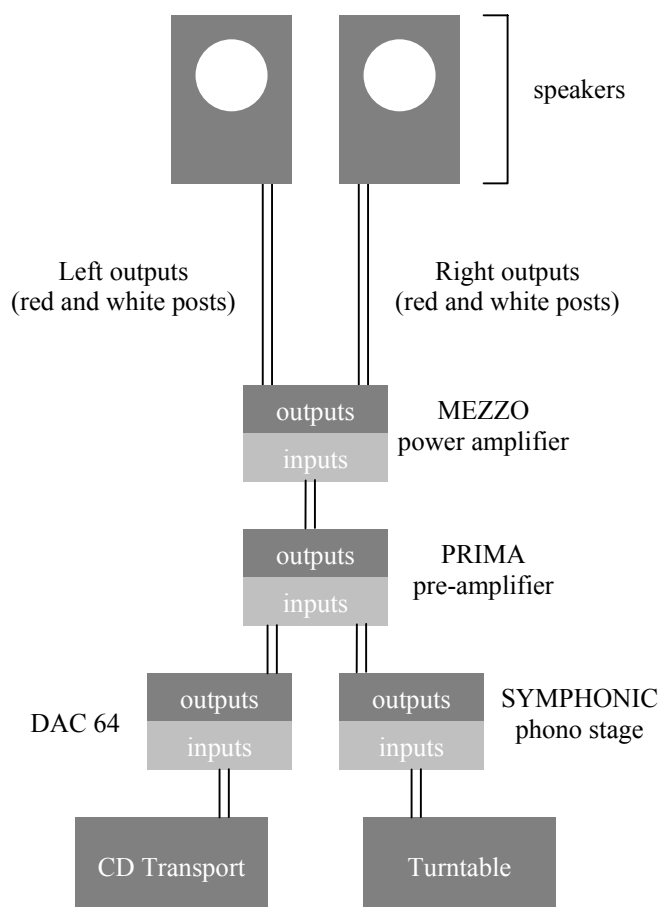

**Normal stereo connections for the MEZZO**

# everyday use of the MEZZO

## **phase switching**

You can choose the phase of the signals that are sent to your loudspeakers, to account for varying speaker configurations. There are two phase shift toggle switches on the MEZZO, one for each output. The diagram on the previous page shows these two switches. When the switches are in their UP position, the signals at the outputs is inverted by 180 degrees. When the switches are in their DOWN position, the signals at the outputs are non-inverted, with no phase shift.

## **automatic shutdown**

1. If there is a major overload or short circuit the MEZZO will detect this and shut down automatically and the amplifier will go into 'bounce mode'. When in bounce mode, the visible interior of the MEZZO will flash with blue illumination. The MEZZO should then be switched off immediately at the mains.
  
2. When the fault has been rectified the power amplifier can be switched on and will power up as usual. You should wait at least two minutes before turning the amplifier on again at the mains to allow the power supply protection circuitry to reset itself.

# maintenance of the MEZZO

## **cleaning**

To clean finger marks and other blemishes from your amplifier spray clear glass cleaner onto a soft lint free cloth and then use the cloth to gently clean your amplifier.

## **servicing**

There are no user serviceable parts in your Chord amplifier, and it should only be serviced by Chord Electronics Limited or their expressly approved Service Agents.

# frequently asked questions about the MEZZO

**the amplifier is on and the switches are on but there is no sound coming out**

Have you pressed the correct output from your pre-amplifier?

**the sound is vague and ill defined**

Check that both loudspeakers are connected correctly (+ve to +ve or red to red, and -ve to -ve or white to white) on both sides.

**there is a buzzing sound coming from the loudspeakers**

The system may not be properly earthed or the interconnect cables may be running near to mains cables.

**I have connected my 3-channel amplifier to my processor and the main left and right out of my AV processor in to my hi-fi, but there is very little sound coming out of the left and right speakers**

Have you set the volume on your stereo pre-amplifier to the correct gain to match the other channels in the system?

**the sound is vague and ill defined**

Check that both phase switches are in the correct position for stereo or bridged mono use. See pages 26 and 29.

# balanced outputs on the SYMPHONIC

You need to connect the outputs on the back of your SYMPHONIC to a pre-amplifier, which in turn will feed a signal to a power amplifier in order to drive your loudspeakers. There is a pair of balanced XLR outputs, which will drive a 68Ω load.

## connecting to your pre-amplifier

Use the XLR style output connectors to connect your SYMPHONIC to the XLR style input connectors of your PRIMA or any other model of pre-amplifier. Ensure that you connect the left output on the SYMPHONIC to your left input on your pre-amplifier. Also the right output on the SYMPHONIC should be connected to the right input on your pre-amplifier.



**Balanced outputs on the SYMPHONIC**

# unbalanced outputs on the SYMPHONIC

You need to connect the outputs on the back of your SYMPHONIC to a pre-amplifier, which in turn will feed a signal to a power amplifier in order to drive your loudspeakers. All Chord equipment is designed to be used with balanced connections to maximise audio signal quality. However there is also a pair of unbalanced outputs as well in case your pre-amplifier does not have balanced inputs.

## **connecting to your pre-amplifier**

Use the phono style output connectors to connect your SYMPHONIC to the phono style input connectors of your pre-amplifier. Ensure that you connect the left output on the SYMPHONIC to your left input on your pre-amplifier. Also the right output on the SYMPHONIC should be connected to the right input on your pre-amplifier.

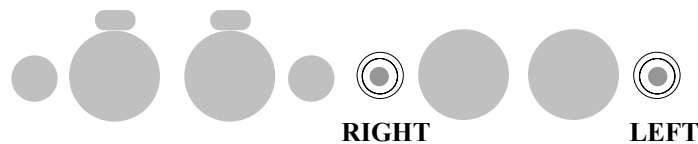

**Unbalanced outputs on the SYMPHONIC**

# balanced inputs on the SYMPHONIC

You need to connect the outputs on your turntable inputs of your SYMPHONIC phono stage, which in turn will feed a signal to a pre-amplifier. The signal will then pass onto a power amplifier in order to drive your loudspeakers. There is a pair of balanced XLR inputs on your SYMPHONIC phono stage.

## connecting to your phono stage

Use the XLR style input connectors to connect your SYMPHONIC to the XLR style output connectors of your turntable. Ensure that you connect the left output of your turntable to the left input on your SYMPHONIC. Also the right output on the turntable should be connected to the right input on your SYMPHONIC.

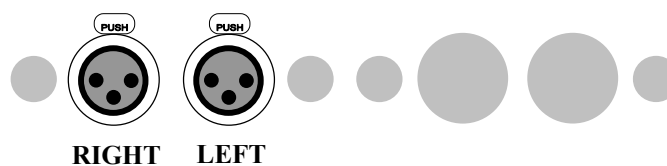

**Balanced inputs on the SYMPHONIC**

# unbalanced inputs on the SYMPHONIC

You need to connect the outputs on your turntable inputs of your SYMPHONIC phono stage, which in turn will feed a signal to a pre-amplifier. The signal will then pass onto a power amplifier in order to drive your loudspeakers. All Chord equipment is designed to be used with balanced connections to maximise audio signal quality. However there is also a pair of unbalanced inputs as well in case your turntable does not have balanced outputs.

## **connecting to your turntable**

Use the phono style input connectors to connect your SYMPHONIC to the phono style output connectors of your turntable. Ensure that you connect the left output of your turntable to the left input on your SYMPHONIC. Also the right output on the turntable should be connected to the right input on your SYMPHONIC.

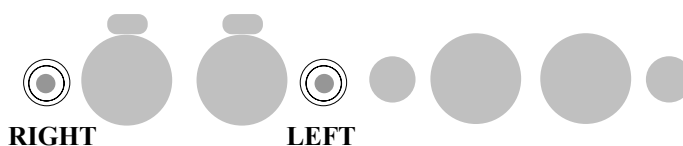

**Unbalanced inputs on the SYMPHONIC**

# earthing connections on the SYMPHONIC

You need to ensure that the earth on your turntable and phono stage is correctly matched. It is important that the electronic circuitry in your turntable and phono stage are referencing to the same earth point in order to achieve the best possible sound quality for the playback of your vinyl recordings.

## **connecting the earth on your turntable to the SYMPHONIC**

Use the earthing point on your SYMPHONIC to connect to the earth connection on your turntable. The earthing point is situated just above the right phono output on the SYMPHONIC phono stage.

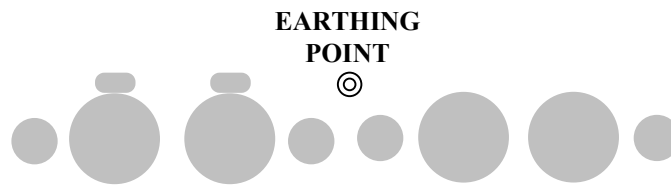

**Earthing point on the SYMPHONIC**

# everyday use of the SYMPHONIC

Above the input and output connectors on the back of the SYMPHONIC are a set of 12 selector switches. These are used to select balanced or unbalanced inputs, set the input impedance, set the input gain and select an optional rumble filter.

## using the rumble filter

The rumble filter is a form of Rausch filter. This is essentially a high pass filter that is used to remove certain low frequencies caused by turntable deck rumble whilst allowing all of the frequency content of the music being played through. To activate the rumble filter press the rumble filter switch in. To de-activate the rumble filter, simply press the rumble switch again to release the switch.

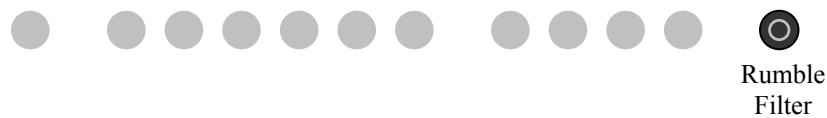

**Rumble filter switch**

## selecting input gain

There are four selector switches to the left of the rumble filter selector switch that are used to set up the required input gain on the SYMPHONIC. The four input gain selection switches allow a choice between four values of input gain to be added into the input signal path. These multiple options are very useful when you are adjusting the input gain on the SYMPHONIC in order to match with the performance of the output stages of your turntable. To add a particular input gain into the signal path, press the appropriate switch in. To remove a selected input gain, simply press the switch again to release the switch.

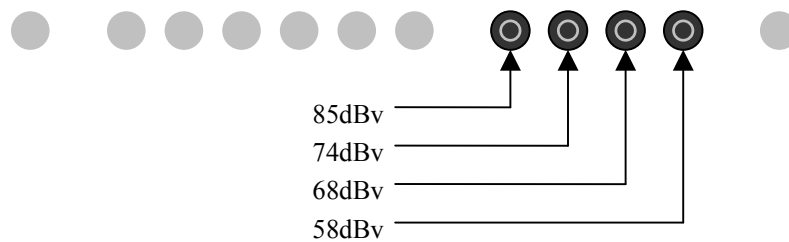

**Input gain selection switches**

**selecting input impedance**

There are six selector switches to the left of the input gain selector switches that are used to set up the required input impedance on the SYMPHONIC. Without using any additional impedance the SYMPHONIC features 50pF input impedance when using unbalanced inputs. If you are using balanced inputs then all impedance values are doubled. The six input impedance selection switches allow six values of impedance to be added into the input signal path. These multiple options are very useful when you are adjusting the input impedance on the SYMPHONIC in order to match with the performance of the output stages of your turntable. To add a particular input impedance into the signal path, press the appropriate switch in. To remove a selected input impedance, simply press the switch again to release the switch.

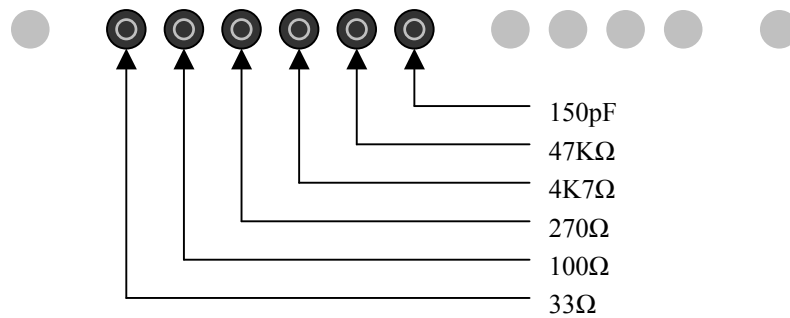

**Input impedance selection switches**

**selecting balanced or unbalanced inputs**

The selector switch that is situated furthest left is the balanced / unbalanced input selector switch. If you wish to use balanced input connections press this switch in. If you are using unbalanced input connections that this switch should be out.



**Balanced / unbalanced input selection switch**

# settings on the SYMPHONIC

On the top panel of the aluminium chassis of the SYMPHONIC, there are two glass domes. Under the glass domes, there are LEDs that illuminate to show the current settings that are selected on the SYMPHONIC. For each setting that you make on the selector switches on the back of the SYMPHONIC, a pair of coloured LEDs will light on the boards below the glass domes on the top panel of the SYMPHONIC.

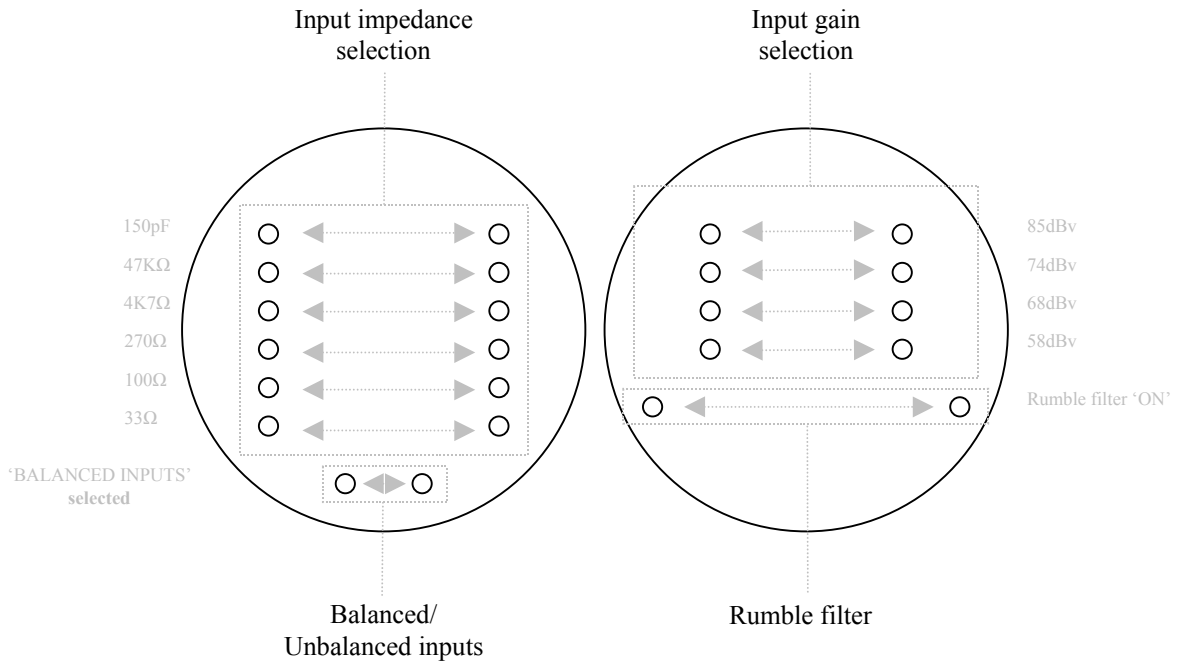

## LEDs featured on the SYMPHONIC

# maintenance of the SYMPHONIC

## **cleaning**

To clean finger marks and other blemishes from your phono stage spray clear glass cleaner onto a soft lint free cloth and then use the cloth to gently clean your Chord product.

## **servicing**

There are no user serviceable parts in your Chord product, and it should only be serviced by Chord Electronics Limited or their expressly approved Service Agents.

# frequently asked questions about the SYMPHONIC

## **can I use any combination of impedance selections when matching the SYMPHONIC to my turntable?**

Yes, the impedance selections provide a wide range of various impedance values in mixed combinations to offer greater versatility and to aid integration with a variety of different turntables.

## **what is RIAA equalisation and the RIAA curve?**

RIAA equalisation is a special form of equalisation that is employed when creating vinyl recordings and cuts lower frequencies in the process. This is used to reduce wide grooves that are difficult for a turntable stylus to follow and also increases the recording time available on a vinyl disc. The RIAA curve is a set standard for frequency response of filters used when playing back vinyl recordings, used to restore lower frequencies that were reduced at the recording stage.

## **balanced connections are being used in my system and there are noticeable differences in the left and right channels.**

Use the balanced input selection switch on the back of the SYMPHONIC by pressing the selector switch in to select balanced inputs.

## **why is there humming coming from the loudspeakers?**

Check that you've earthed the SYMPHONIC to the turntable in your system. This will ensure that the circuitry inside your turntable and phono stage is using the same earth reference point.

# balanced outputs on the DAC 64

You need to connect the outputs on the back of your DAC 64 to a pre-amplifier, which in turn will feed a signal to a power amplifier in order to drive your loudspeakers. There is a pair of balanced XLR outputs, which will drive a 68Ω load.

## connecting to your pre-amplifier

Use the XLR style output connectors to connect your DAC 64 to the XLR style input connectors of your PRIMA or any other model of pre-amplifier. Ensure that you connect the left output on the DAC 64 to your left input on your pre-amplifier. Also the right output on the DAC 64 should be connected to the right input on your pre-amplifier. If you are using the PRIMA pre-amplifier to connect to the DAC 64 then use the gain setting x0.50. If you using any other Chord pre-amplifier or integrated amplifier then use the gain setting x1.00.

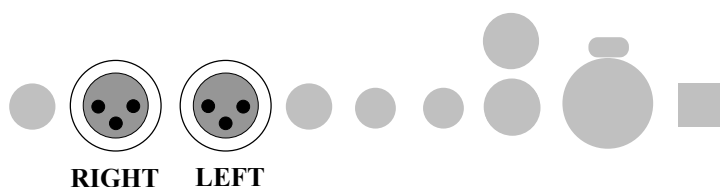

**Balanced outputs on the DAC 64**

## phase inverted outputs

It is important to know that the outputs of DAC 64 are phase inverted i.e. on the XLRs the positive and return pins are American style not Euro style. If the DAC 64 is used outside a Chord system, you must either swap over the speaker connectors or use XLR to RCA leads with the phase inversion built into the leads.

# unbalanced outputs on the DAC 64

You need to connect the outputs on the back of your DAC 64 to a pre-amplifier, which in turn will feed a signal to a power amplifier in order to drive your loudspeakers. All Chord equipment is designed to be used with balanced connections to maximise audio signal quality. However there is also a pair of unbalanced outputs as well in case your pre-amplifier does not have balanced inputs.

## connecting to your pre-amplifier

Use the phono style output connectors to connect your DAC 64 to the phono style input connectors of your pre-amplifier. Ensure that you connect the left output on the DAC 64 to your left input on your pre-amplifier. Also the right output on the DAC 64 should be connected to the right input on your pre-amplifier.

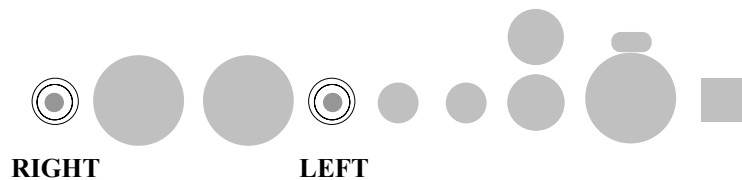

**Unbalanced outputs on the DAC 64**

# digital inputs on the DAC 64

The DAC 64 comes equipped with four digital inputs, allowing compatibility with virtually any digital audio source equipment. Digital audio source equipment includes CD transports, DVD players and Mini Disc players. The four digital inputs consist of two 75ohm-SP/DIF2 BNC coaxial input (COAXIAL), one AES balanced XLR input (AES) and one Plastic Fibre Optical input (OPTICAL).

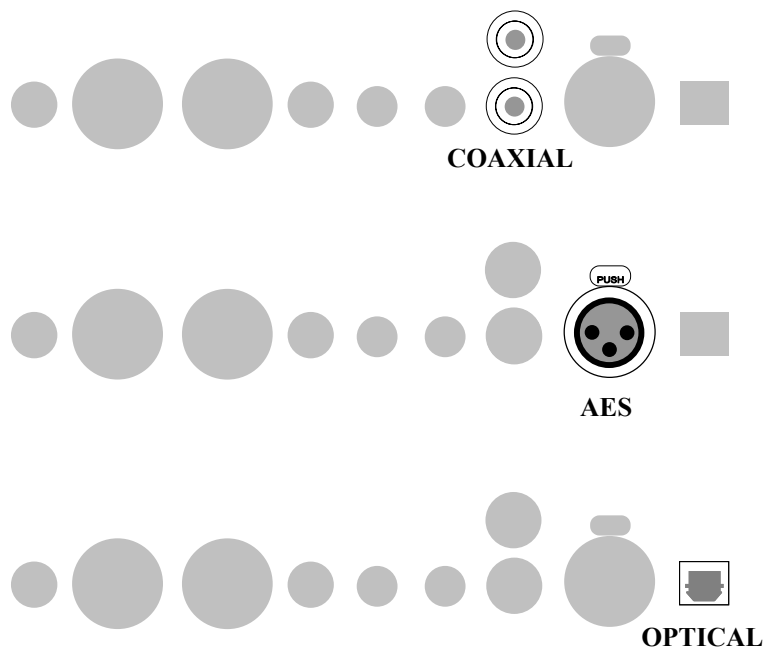

**Digital inputs on the DAC 64**

# everyday use of the DAC 64

## selecting a digital input

Once you have connected your digital audio source equipment to the digital input connections on the DAC 64, you need to select your chosen input by using the digital input selection toggle switch on the back panel of the unit. The switch is located next to the COAX input.

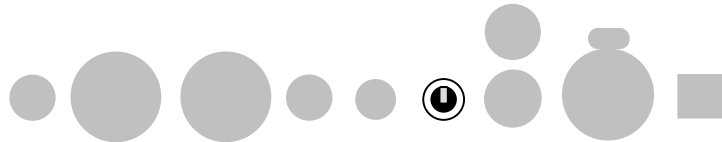

**Digital input selection toggle switch**

On powering the unit there should be a blue glow from the central located glass window. Once the DAC 64 has achieved a digital lock on the selected incoming signal, an additional set of hidden red light emitting diodes (LEDs) will illuminate changing the overall glow to a purple colour.

Each of the four different digital inputs are selected by changing the position of the digital input selection toggle switch. The top position of the toggle switch is used for the plastic fibre optical input (OPTICAL). The middle position of the toggle switch is used for the AES balanced XLR input (AES). The bottom position of the toggle switch is used for the 75ohm-SP/DIF2 BNC coaxial inputs (COAXIAL).

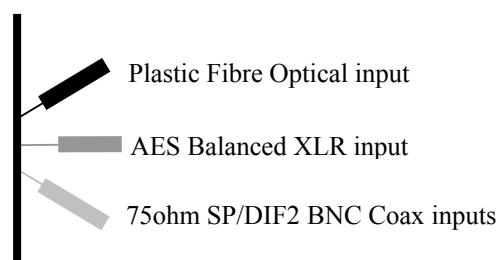

**Position settings for the digital input selection toggle switch**

Either or both of the two BNC (COAXIAL) inputs can be used and selection is automatic once the toggle switch is in the lower position. If you are using two different sources with BNC connections switch off the source not in use to activate the other input. For Dual Data 192 kHz mode use both BNC inputs from a dual data, 192 kHz compatible transport. If both BNC's are used make sure that the BNC source(s) is (are) switched off when using either the AES or optical inputs.

### buffer settings

buffering is a processing operation where the digital input signal is stored in RAM (random access memory) for a period of time before it is passed through the DAC 64. This period of time allows the DAC 64 to analyse the input signal for any errors and to correct them.

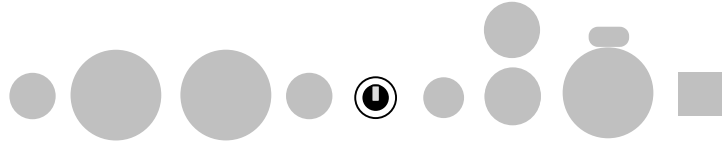

### Buffer setting toggle switch

There are three buffer settings to choose from. These are no buffering, minimum buffering and maximum buffering. The three buffer settings are chosen using the buffer setting toggle switch. The top position of the toggle switch is used for the no buffering setting. The middle position of the toggle switch is used for the minimum buffering setting. The middle position of the toggle switch is used for the maximum buffering setting.

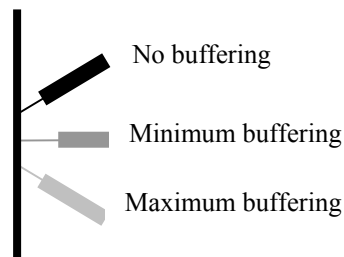

### Position settings for the buffer setting toggle switch

When using the DAC 64 with the buffer set to minimum, there is a time delay of 2 - 3 seconds from triggering your digital input source equipment to play to actually hearing music. On the maximum setting this is 4 - 5 seconds. Whenever switching between the different buffer settings there is a delay of approximately 4 seconds before play resumes.

Whenever buffering is activated, in either minimum or maximum settings, an additional set of hidden yellow LEDs will illuminate.

# maintenance of the DAC 64

## **cleaning**

To clean finger marks and other blemishes from your DAC 64 spray clear glass cleaner onto a soft lint free cloth and then use the cloth to gently clean your Chord product.

## **servicing**

There are no user serviceable parts in your Chord product, and it should only be serviced by Chord Electronics Limited or their expressly approved Service Agents.

# frequently asked questions about the DAC 64

## **there is no output from the DAC once everything has been connected and the digital source is playing**

It may be that the DAC has not set itself. Switch off the DAC 64 at the power switch (see powering down on page 7), and wait for 30 seconds before powering up. This should be enough time for the DAC to configure itself.

## **how does the DAC 64 handle de emphasis coding?**

The DAC 64 will automatically detect when a pre-emphasised recording is being played, and will set the correct de-emphasis filters in the converter section.

## **are there any precautions before I make changes to the positioning of the toggle switches on the DAC 64?**

It is important to set the volume on the pre-amplifier to minimum when switching between digital inputs or setting the Ram buffer on the DAC64.

## **can the DAC 64 be used in an AV system to handle the audio?**

The DAC 64 is an ideal component in any system requiring digital to analogue conversion of stereo digital audio signals. Do not use any buffering, as the audio will be out of sync with the video on your display device. Also make sure that the digital output on your DVD player is set to PCM.

## **how does the DAC 64 work?**

The design of the digital to analogue circuitry has been implemented with great care. The DAC 64 is the first model to be introduced which features a radically new type of filter called the Watts Transient aligned filter. It also includes the latest generation Pulse Array DAC, 64-bit filter and DAC architecture, and an all new digital receiver chip.

The receiver chip takes the data from the transport and generates clocks and data in a form that the filter can accept. The new chip has two major benefits – all digital data extraction and a RAM buffer. This RAM buffer sequentially takes all the data, retimes it, and sends it out. The RAM buffer allows the jitter free local clock operation without needing to send back a clock signal to the data source.

## **are there any special requirements to ensure compatibility of the DAC 64 with equipment made by other manufacturers?**

It is important to know that the outputs of DAC 64 are phase inverted. If the DAC 64 is used outside a Chord system, you must either swap over the speaker connectors or use XLR to RCA leads with the phase inversion built into the leads.